

Catalogo tecnico
Technical handbook
Technischer katalog
Catalogue technique

2011

RACCORDI E ACCESSORI PER CONDOTTE INTERRATE IN PVC

PVC DRAINAGE AND SEWAGE SYSTEMS

PVC-U ENTWÄSSERUNGSSYSTEME

RACCORDS PVC ASSAINISSEMENT

ACCESORIOS SANEAMIENTO EN PVC

EN1401

www.redi.it

REDI
le strade dell'acqua





REDI è amica dell'ambiente certificata ISO 14001 / REDI an Ecofriendly company ISO 14001

INDICE / Index

Introduzione / Introduction	pag. 2
Certificazioni / Certificates	pag. 3
La gamma / Product range	pag. 4
Voci di capitolato / Product specification	pag. 5÷7
Referenze fotografiche / Photo references	pag. 8÷9
Valvole antiriflusso OTTIMA / Non-return valves OTTIMA	pag. 10÷11
Curve SN8 SDR34 / Bends SN8 SDR34	pag. 12
Derivazioni SN8 SDR34 / Branches SN8 SDR34	pag. 12
Curve / Bends	pag. 13÷15
Giunto snodato 160 / Swivel	pag. 15
Derivazioni / Branches	pag. 16÷21
Ispezioni / Inspections	pag. 21
Tappi / Access plugs	pag. 22÷23
Aumenti / Reducers	pag. 24
Collegamenti / PVC clay adaptors	pag. 25
Manicotti / Couplers	pag. 26÷27
Sifoni / Trap interceptors	pag. 28
Valvole antiriflusso / Non-return valves	pag. 29÷31
Valvole Clapet / Non-return Clapet	pag. 32
Pozzetti / Inspection chambers	pag. 33÷35
Sifoni / Traps	pag. 36
Selle / Saddles	pag. 37
Clip meccanica / Mechanical saddle	pag. 38÷39
Easy Clip (not available for sale in Germany)	pag. 40÷42
Attrezzature / Equipment	pag. 43
Certificazioni prodotti / Product certificates	pag. 44

L'azienda, normative di riferimento

Attiva da oltre 40 anni REDI è specializzata nella produzione di raccordi e pezzi speciali in materiale plastico per la realizzazione di condotte fognarie e reti idrosanitarie.

Gamma completa, altissima qualità dei prodotti e dei servizi costituiscono da sempre l'offerta che REDI rivolge ai Clienti nell'ottica di stabilire e consolidare duraturi rapporti commerciali.

REDI con il Certificato n.047 rilasciato il 01.01.94 dal SQP (Sistema di certificazione Qualità aziendale gestito dall'IIP) ha ottenuto il riconoscimento formale del proprio impegno per la qualità.

La certificazione ottenuta secondo le norme UNI EN 9001: 2008 dimostra che ogni fase lavorativa dall'approvvigionamento delle materie prime alla fabbricazione, dal collaudo del prodotto alla sua distribuzione, segue delle procedure che consentono di fornire all'utenza prodotti e servizi di qualità.

REDI è inoltre particolarmente sensibile al rispetto dell'ambiente e la certificazione ISO 14001 ottenuta dimostra l'affidabilità del sistema di gestione ambientale applicato ed è la prova del nostro impegno teso a ridurre al minimo l'impatto sull'ambiente dei nostri processi.

In particolare la gamma REDI è composta da:

- Raccordi e pezzi speciali con guarnizione a labbro in pvc per condotte fognarie (EN 1401)
- Camere di ispezione in PVC e PP (AFNOR-ANF)
- Valvole antiriflusso in PVC (d. 100 ÷ 400) EN13564
- Tubi e raccordi in PVC a incollaggio per lo scarico all'interno dei fabbricati (EN 1329 / AFNOR ENF)
- Phonoline: tubi e raccordi per scarico insonorizzato 15 dB (EN 14366) e ininfiammabile (EN13501-1 - Classe B S2 d0)
- Tubi e raccordi in PP a innesto per lo scarico all'interno dei fabbricati (EN 1451)
- Tubi e raccordi in PE a saldare per lo scarico all'interno dei fabbricati (EN 1519)
- Tubi e raccordi in PPR e PEX per adduzione idrosanitaria
- Prodotti per il drenaggio suolo
- Griglie di ventilazione

REDI appartiene al Gruppo Aliaxis, leader mondiale nel settore dei materiali plastici per acqua e gas.

La Società si riserva la facoltà di apportare, in qualsiasi momento e per ragioni di miglioramento tecnico dei prodotti, le variazioni che riterrà opportune sugli articoli indicati nel presente catalogo che pertanto ha carattere indicativo

The company, norms

REDI has been producing plastic fittings for over 40 years, becoming a highly advanced and successful company.

The reason for this success is our constant effort in offering the most comprehensive service to our Clients aiming at establishing long-lasting and profitable business relationships.

REDI is certified in accordance with quality standards UNI EN ISO 9001:2008.

REDI manufactures and offers the following product ranges:

- PVC rubber ring-sealed fittings for underground drainage (EN 1401)
- PVC and PP inspection chambers (AFNOR-ANF)
- PVC anti-flooding valves (DN 100 ÷ 630)
- U-PVC solvent weld fittings for above ground drainage (EN 1329 - AFNOR-ENF)
- Phonoline: soundproof piping system 15 dB (EN 14366)
- PP pipes and fittings for non-pressure above ground drainage (EN 1451)
- Surface drainage systems
- Ventilation

REDI is part of Aliaxis group, world leader in the manufacture of building materials.

The Company operates a policy of progressive improvements and reserves the right to alter the specification of any product without prior notice. Information given by way of illustrations and dimensions is intended to assist the Buyer but where such information is of paramount importance it should be confirmed with the Company in writing before any order is placed.



9001: 2008



ISO 14000

Dimensioni / Sizes	EN1401
Resistenza all'urto / <i>Shock resistance</i>	EN12061
Resistenza meccanica (Raccordi Fabbricati o Termoformati) <i>Mechanical stress resistance (Fabricated or thermoformed fittings)</i>	EN12256
Temperatura di rammollimento Vicat / <i>Vicat softening temperature</i>	EN727
Effetti del riscaldamento / <i>Heating effects</i>	EN580
Tenuta idraulica (Raccordi Fabbricati o Termoformati) <i>Water tightness (Fabricated or thermoformed fittings)</i>	EN1053
Tenuta delle guarnizioni elastomeriche* / <i>Elastomeric sealing tightness*</i> * (con deformazione diametrale e flessione angolare alle seguenti condizioni +0,05 bar, +0,5 bar, -0,3 bar) * (With diametrical elastic failure and angular bending under the following conditions +0,05 bar, +0,5 bar, -0,3 bar)	EN1277
Cicli ad alta temperatura / <i>High temperature cycle</i>	EN1055
Resistenza alla pressione / <i>Pressure Strength</i>	EN1167

L'elenco delle corrispondenze tra i marchi indicati e i prodotti a catalogo é disponibile a richiesta.
The list of the correspondence between these Certificates of Conformity and the products described in this Technical Handbook is available upon request.



IIP EN 1401



MPA EN 1401



AFNOR-CSTB: NF-A / 1401-1



Ö Norm: EN1401



BSI: EN 1401

Una gamma completa per la fognatura

A complete range of fittings for underground drainage

In questa pagina abbiamo schematizzato un sistema di scarico che ha inizio dall'abitazione con il sistema fonoassorbente Phonoline, che si congiunge attraverso una serie di raccordi e pezzi speciali per la fognatura alla rete comunale.

REDI permette di realizzare un sistema di scarico rispondente alle norme vigenti e certificata da Istituti internazionali, scegliere REDI significa garantire affidabilità e sicurezza d'esercizio.

Sul sito internet www.redi.it sono disponibili voci di capitolato, certificazioni aggiornate, schede tecniche e librerie in formato cad.

Redi offers complete drainage solutions starting from the soundproof "Phonoline" for aboveground drainage to private sewers and connections onto public mains.

Redi fittings and ancillary equipments are fully certified by European Standard Institute allowing the design of drainage systems complying with local Building Regulations.

Redi provides easy-to-install, secure and reliable solutions aiming at building long-lasting networks.

Product specifications, updated certifications, technical data sheets and AutoCAD drawings may be downloaded from our site www.redi.it

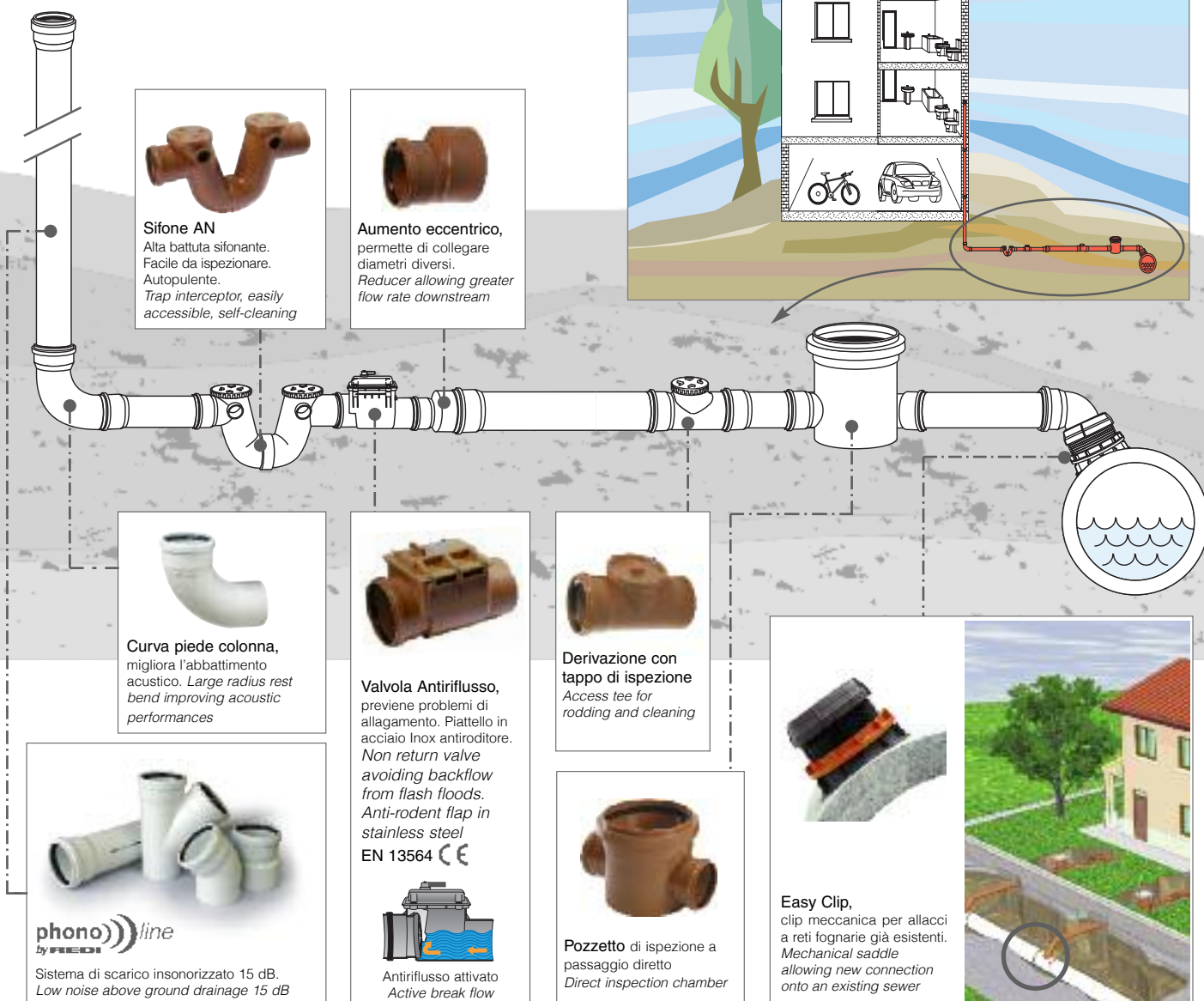
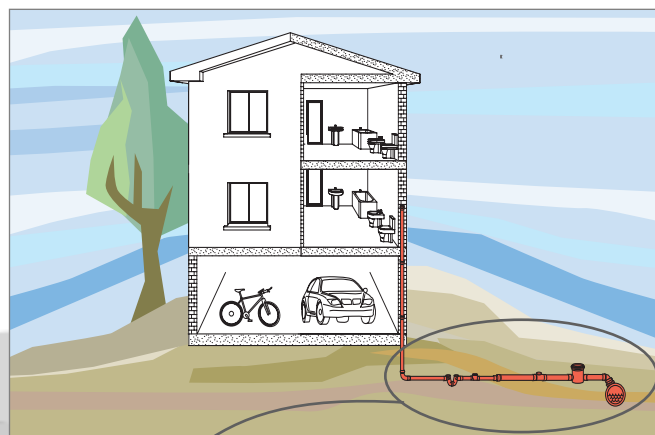

Voci di capitolato

Tubi e raccordi fognatura

Fornitura e posa in opera di tubi e raccordi di PVC rigido, adatti alla realizzazione di condotte destinate al convogliamento di reflui di scarico non in pressione, fognature civili, industriali e agricole.

Le caratteristiche tecniche dei raccordi sono conformi alla normativa EN 1401, la gamma dimensionale copre i diametri dal DN 110 al DN 630*.

Il sistema di giunzione è di tipo a bicchiere con guarnizione di tenuta a labbro.

Le giunzioni sono realizzate con guarnizioni a labbro amovibili costruite e certificate conformemente alle norme EN 681-1 e DIN 4060.

Tubi e raccordi dovranno essere marcati riportando:

- identificazione del fabbricante
- l'organismo di certificazione del prodotto è accreditato dal Sincert (es. IIP o equivalente)
- riferimento alla norma EN 1401
- codice di applicazione U o UD
- materiale
- dimensione nominale DN
- angolo nominale (sui raccordi)
- data di produzione

Il fabbricante delle tubazioni e dei raccordi dovrà, pena la non accettazione del materiale, essere certificato per lo standard UNI-EN-ISO 9001:2008.

* Per le dimensioni dei raccordi vedi da pag. 11 a pag. 27.

Sifone in PVC Redi A-N

Fornitura e posa in opera di sifone in PVC stampato per iniezione termoplastica di dimensioni conformi alle norme EN 1329 e EN 1401.

Il sifone dovrà avere i seguenti requisiti tecnici:

- corpo esente da saldature manuali;
- sistema di giunzione ad incollaggio oppure con guarnizione monolabbro;
- altezza della battuta sifonante adeguata per consentire una perfetta sifonatura (almeno 3/10 diametro in cm d'acqua)
- ispezionabilità totale mediante due tappi a vite con guarnizione in elastomero per la tenuta idraulica.
- doppia predisposizione per la connessione della colonna di ventilazione secondaria.

Il fabbricante dovrà, pena la non accettazione del materiale, essere certificato per lo standard UNI-EN-ISO 9001:2008.

* Per le dimensioni vedere pag. 28.

Product Specifications

Sewer fittings

Made of PVC-U for non pressure underground drainage and sewage applications.

Application area code "U" and "UD" where applicable. Nominal ring stiffness and standard dimension ratio as specified in the Redi technical handbook.

Product range from DN.110 up to DN.630 manufactured in compliance with the European Norm EN1401-1.

Sealing lip-rings conform to EN681-1 and DIN4060

Marking :

- *Manufacturer's name*
- *Third party certification (where applicable) IIP, DIN, NF or BS*
- *Number of standard EN1401*
- *Application area code either U or UD*
- *Material either PVC-U, U-PVC or PVC*
- *Nominal angle for fittings only*
- *Nominal size*
- *Nominal ring stiffness or SDR*

Suppliers will attest that they have an ISO9001 approved quality system in place as a condition for purchase.

REDI Trap Interceptors

Injected molded sewer trap made of PVC-U designed for connections to piping systems conform to EN1329 and EN1401.

Redi trap interceptor has the following technical features:

- *No hand welding*
- *SCJ or RRJ jointing type*
- *Optimal water seal (min. 3/10 diameter ratio) to prevent the passage of sewer gas*
- *Provided with 2 rodding access screw caps*
- *Blank vents inlets for the relief of sewer gases, admission of oxygen for aerobic sewage digestion and maintenance of the trap water seal*

Suppliers will attest that they have an ISO9001 approved quality system in place as a condition for purchase.

Valvola antiriflusso

Valvola antiriflusso di tipo 1 dotata di dispositivo di chiusura automatico e leva di blocco in posizione di chiuso, realizzata per stampaggio ad iniezione PVC non plastificato.

Dimensioni degli innesti conformi alla EN 1401 e EN 1329*; Il sistema di giunzione può essere di tipo ad incollaggio o a bicchiere con guarnizione di tenuta a labbro.

Il dispositivo è completamente ispezionabile, dotato di coperchio amovibile a tenuta idraulica, il piattello di tenuta è asportabile.

Le guarnizioni a labbro amovibili sono costruite e certificate conformemente alle norme EN 681-1 e DIN 4060. Il dispositivo è dotato di marcatura CE.

La valvola è certificata dall'istituto LGA in conformità conforme alla normativa EN 13564-1 (fino Ø200), istituto internazionale specializzato nella certificazione di dispositivi anti allagamento.

Il fabbricante dovrà, pena la non accettazione del materiale, essere certificato secondo lo standard UNI EN ISO 9001:2008.

* Per le dimensioni vedere le pag. 29 - 30.

Pozzetto d'ispezione a passaggio diretto in PVC/PP

Fornitura e posa in opera di pozzetto d'ispezione in PVC/PP rigido a totale tenuta idraulica, prodotto mediante stampaggio ad iniezione.

Il pozzetto si caratterizza per il sistema di connessione ad anello di tenuta, conforme alla norma EN 1401*/ EN1852.

Le guarnizioni a labbro amovibili sono costruite e certificate conformemente alle norme EN 681-1 e DIN 4060.

La base pozzetto è realizzata in modo da garantire la continuità idraulica, è di sezione semicircolare pari al diametro del tubo che si innesta, per non creare interruzione di flusso, garantisce caratteristiche autopulenti, evita il deposito di detriti, favorisce lo scorrimento in caso di scarsa portata.

Il pozzetto consente il collegamento con il piano stradale mediante prolunga Ø400 in PVC/PP collegata alla base pozzetto tramite guarnizione a labbro.

L'elemento di coronamento stradale, ha la possibilità di essere regolato alla quota desiderata metricamente, grazie al sistema ad innesto telescopico. La copertura deve rispettare le condizioni di carrabilità richieste, i regolamentazioni locali.

Il fabbricante delle tubazioni e dei raccordi dovrà, pena la non accettazione del materiale, essere certificato per lo standard UNI-EN-ISO 9001:2008.

* Per le dimensioni vedere da pag. 32 a pag. 34.

Non Return Valves

Injected molded non return valves made of PVC-U designed for connections to piping systems conform to EN1329 and EN1401.

One-flap device with locking lever certified EN 13564 Type 1.

SCJ or RRJ jointing type (Sealing lip-rings conform to EN681-1 and DIN4060)

Moving parts shall be detachable or capable of being dismantled on site.

Airtight and watertight sealed cover.

CE marking.

German certification LGA EN13564-1 (DN100 up to DN200)

Suppliers will attest that they have an ISO9001 approved quality system in place as a condition for purchase.

Inspection Chambers

Injected molded non return valve made of PVC-U designed for connections to piping systems conform to EN1401.

RRJ jointing type (Elastomeric ring seal joints conform to EN681-1 and DIN4060)

Half-pipe smooth chamber base allowing running flow and preventing the deposit of debris even at low flow.

The chamber base may be connected to a riser/shaft DN400 (depth depending) terminating at ground level.

The telescopic part allows the settlement that might occur after installation or adjustments of the height of the chamber.

The cover shall conform to specifications (material, loading class, locking devices)

Suppliers will attest that they have an ISO9001 approved quality system in place as a condition for purchase.

Easy Clip **(non è disponibile per il mercato tedesco)**

Realizzazione di allacciamento in fognatura ottenuto tramite dispositivo di innesto ad ancoraggio meccanico, a tenuta idraulica. Il dispositivo è universale, adatto all'installazione su diversi tipi di materiale di tubature fognarie.

La tenuta idraulica è garantita grazie alla guarnizione a sella (mod. brevettato) che aderisce perfettamente alla parete interna del tubo. Il dispositivo una volta installato lascia inalterata la sezione passante del collettore completamente libera.

Il corpo della clip è realizzato in PVC, le guarnizioni in EPDM, per le dimensioni consultare il Catalogo Tecnico Fognatura REDI al capitolo Easy Clip.

Sul lato esterno il dispositivo è munito di giunto a bicchiere con guarnizione di tenuta di tipo a labbro, l'imbocco ha dimensioni conformi alla EN1401.

Il dispositivo è progettato per superare i più elevati standard di prova, resistenza alla pressione, cicli di pulizia (canaljet) ed è certificato da organismi riconosciuti a livello internazionale (CSTB, DIBt).

Il fabbricante dovrà, pena la non accettazione del materiale, essere certificato per lo standard UNI-EN-ISO 9001:2008.

Le voci di capitolato di tutti i prodotti Redi sono disponibili a richiesta.

Easy Clips **(not available for Germany)**

Universal mechanical branch connection onto an existing buried drainage of larger diameter.

Suitable for sewers mains made from different materials (plastic, clay, concrete)

(Refer to the Redi technical handbook for the choice of the appropriate saddle)

Water tightness secured by a profiled sealed gasket (patent pending) allowing limited penetration (no disruption of the flow)

Injected molded parts in PVC-U, inlets designed for connections to piping systems conform to EN1401.

DN160 inlet equipped with swivel allowing pipe rotation 10° balancing ground settlement.

Water tightness, pressure cleaning and negative air tightness certified by DIBt.

Suppliers will attest that they have an ISO9001 approved quality system in place as a condition for purchase.

Available on request the product specifications of the complete range of Redi.

Referenze fotografiche

Photo references

Sifoni per acque nere, esempio di ventilazione secondaria, installazione pozzetto.

Sewer traps, typical installation of a secondary ventilation column, inspection chambers.



Easy Clip è stato utilizzato nella realizzazione degli impianti di scarico grandi diametri della banchina stradale.

Easy Clip è stato utilizzato per gli allacci dalla rete fognaria comunale alle singole abitazione del centro storico.

Easy Clip fit-for-purpose saddles have been successfully installed for conveying surface waters from highway bridges and to connect private sewers to the main collector of Italian historical downtowns.



Valvola antiriflusso Ottima anti-backflow valve



TYPE 2 two flaps

INNOVATIVA

- maggiore sicurezza
- ricerca della funzionalità
- miglioramento delle caratteristiche del prodotto
- nuovi requisiti tecnici

INNOVATIVE

- increased safety
- search for functionality
- improvement of product features
- new technical requirements

Basso dislivello (offset)

Minimum offset



La versione M/M è adatta alle ristrutturazioni, all'installazione su tubi esistenti.

The M/M version is recommended for renovation; installation on existing pipes.

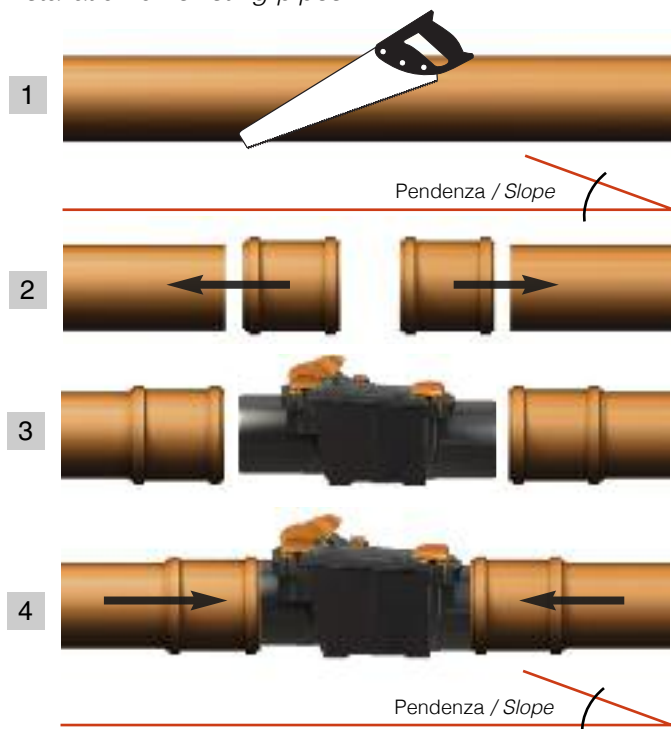

Certificato pag. 44
Certificata pag. 44



Ø100 - Ø110



Ø125 - Ø160

La versione M/M consente l'installazione su qualsiasi tipo di materiale.

The M/M version can be installed on any sort of material.

Giunti di transizione tra materiali diversi
Transition coupling between different materials



Multi-diametro / Multi-diameter
Multi-materiale / Multi-material

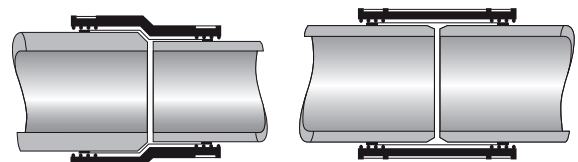
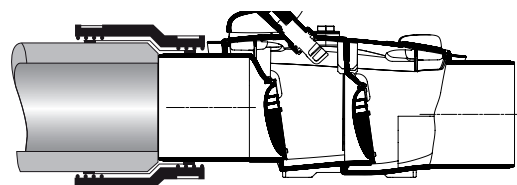



M/F - Guarnizioni - Tutti i plastici lisci ØOD

Single Socket - RRJ - All plastic smooth materials ØOD

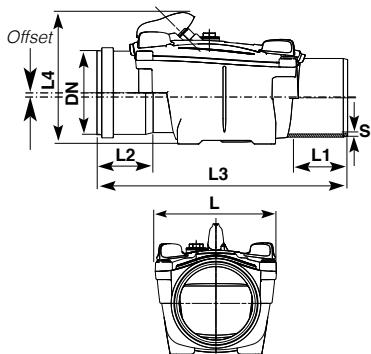

DN	Codice / Ref. Nero/Black	S (mm)	L (mm)	L1 (mm)	L2 (mm)	L3 (mm)	L4 (mm)	Offset (mm)	Piattelli Inox Inox flaps
100	12R1048	3,0	171	60	57	338	184	7	TYPE 2
100	11R1048	3,0	171	60	57	338	184	7	TYPE 1
110	12R1148	3,2	171	65	63	350	184	7	TYPE 2
110	11R1148	3,2	171	65	63	350	184	7	TYPE 1
125	12R1248	3,2	255	73	69	458	226	9	TYPE 2
125	11R1248	3,2	255	73	69	458	226	9	TYPE 1
160	12R1648	4,0	255	83	82	491	226	9	TYPE 2
160	11R1648	4,0	255	83	82	491	226	9	TYPE 1

Guarnizione labbro montata CERTIFICATA EN 681 / Lip Ring CERTIFIED EN 681

M/F - Incollaggio - PVC

Single Socket - SCJ - PVC

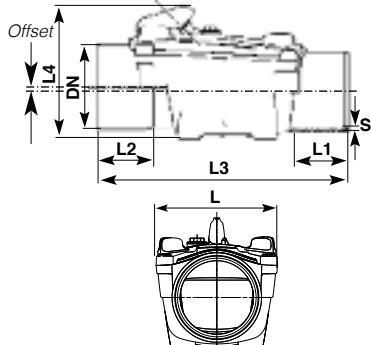

DN	Codice / Ref. Nero/Black	S (mm)	L (mm)	L1 (mm)	L2 (mm)	L3 (mm)	L4 (mm)	Offset (mm)	Piattelli Inox Inox flaps
100	12S1008	3,0	171	60	57	338	184	7	TYPE 2
100	11S1008	3,0	171	60	57	338	184	7	TYPE 1
110	12S1108	3,2	171	65	63	350	184	7	TYPE 2
110	11S1108	3,2	171	65	63	350	184	7	TYPE 1
125	12S1208	3,2	255	73	69	458	226	9	TYPE 2
125	11S1208	3,2	255	73	69	458	226	9	TYPE 1
160	12S1608	4,0	255	83	82	491	226	9	TYPE 2
160	11S1608	4,0	255	83	82	491	226	9	TYPE 1

M/M - Manicotto/Incollaggio - Tutti i materiali/PVC

Spigot/Spigot - All materials/PVC

(*Consigliata nelle ristrutturazioni *Suggested for renovation)

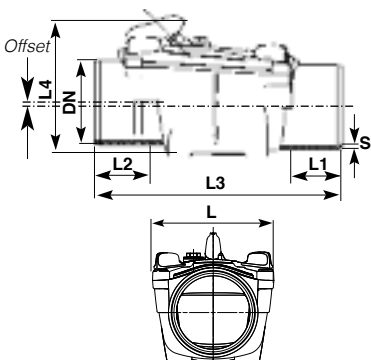

DN	Codice / Ref. Nero/Black	S (mm)	L (mm)	L1 (mm)	L2 (mm)	L3 (mm)	L4 (mm)	Offset (mm)	Piattelli Inox Inox flaps
100	12M10M8	3,0	171	60	57	338	184	7	TYPE 2
100	11M10M8	3,0	171	60	57	338	184	7	TYPE 1
110	12M11M8	3,2	171	65	63	350	184	7	TYPE 2
110	11M11M8	3,2	171	65	63	350	184	7	TYPE 1
125	12M12M8	3,2	255	73	69	458	226	9	TYPE 2
125	11M12M8	3,2	255	73	69	458	226	9	TYPE 1
160	12M16M8	4,0	255	83	82	491	226	9	TYPE 2
160	11M16M8	4,0	255	83	82	491	226	9	TYPE 1

Tutte le figure Ø 110 elencate da pag 13 a pag 20 sono SN8 SDR34

All fittings sized Ø 110 listed from page 13 to page 20 of this catalogue are SN8 SDR34



Curva M/F - Bend S/S - Bögen
Codo M/H - Coude M/F - Bocht mof-spie

SN8 - SDR34

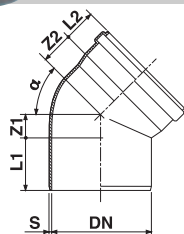

DN	α	S	Z1	Z2	L1	L2	Codice / Ref. RAL 7037 Grigio/Grey (*)	TIPO
125	45°	3,7	29	40	68	56	0702242*	SN8 SDR34
160	15°	4,7	14	28	82	72	0101742*	SN8 SDR34
160	45°	4,7	37	51	80	66	0701542*	SN8 SDR34



Curva F/F - Bend D/S - Bögen M/M
Codo H/H - Coude F/F - Bocht mof-mof

SN8 - SDR34

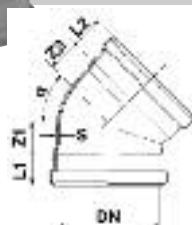

DN	α	S	Z1	Z2	L1	L2	Codice / Ref. RAL 7037 Grigio/Grey (*)	TIPO
125	45°	3,7	43	43	62	62	0232242*	SN8 SDR34
160	15°	4,7	28	28	73	73	0211742*	SN8 SDR34
160	45°	4,7	49	49	73	73	0231542*	SN8 SDR34



Derivazione ridotta 45° M/F - Branch 45° D/S
Abzweige 45° - Derivación 45° M/H
Embranchement 45° M/F - T-Stuk 45° mof-spie

SN8 - SDR34

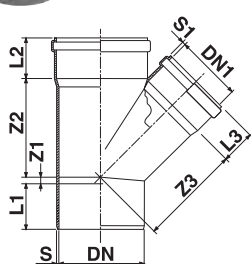

DN	DN1	S	S1	Z1	Z2	Z3	L1	L2	L3	Codice / Ref. RAL 7037 Grigio/Grey (*)	TIPO
160	125	4,7	3,7	12	180	185	83	74	62	0313442*	SN8 SDR34



Derivazione ridotta 45° F/F - Branch 45° D/S
Abzweige 45° - Derivación 45° M/H
Embranchement 45° M/F - T-Stuk 45° mof-spie

SN8 - SDR34

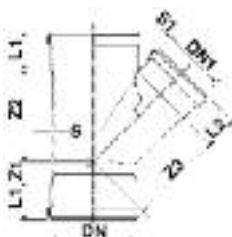

DN	DN1	S	S1	Z1	Z2	Z3	L1	L3	Codice / Ref. RAL 7037 Grigio/Grey (*)	TIPO
160	125	4,7	3,7	41	180	185	74	62	0311932*	SN8 SDR34
200	125	5,9	3,7	54	228	232	86	74	0313932*	SN8 SDR34
200	160	5,9	3,7	54	228	232	86	74	0312232*	SN8 SDR34

* Disponibile su richiesta per minimi quantitativi / Available on request for minimum order.







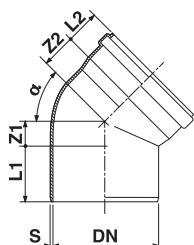

Guarnizione labbro bloccata / Fixed Ring Guarnizione labbro montata / Lip Ring

Always chamfer cut pipe and lubricate all plain ended spigots for perfect push-fit

Curva M/F - Bend S/S

Bögen - Codo M/H - Coude M/F - Bocht mof-spie



DN	α	S	Z1	Z2	L1	L2	Codice / Ref.	
							RAL 7037 Grigio/Grey (*  )	RAL 8023 Rosso/Red 
110	15°	3.2	9	22	62	50	0101142*	0101151
	30°	3.2	17	29	61	50	0111142*	0111151
	45°	3.2	27	36	58	50	0121142*	0121151
	67°30'	3.2	41	53	62	56	0131142*	0131151
	87°30'	3.2	59	69	58	50	0711142*	0711151
125	15°	3.2	10	22	68	63	0101242*	010125E
	30°	3.2	19	29	68	62	0111242*	011125E
	45°	3.2	29	40	68	56	0701242*	0701251
	67°30'	3.2	46	60	69	62	0131242*	013125E
	87°30'	3.2	65	77	67	56	0711242*	0711251
160	15°	4.0	14	28	82	72	0101642*	0101651
	30°	4.0	25	40	82	72	0111642*	0111651
	45°	4.0	37	51	80	66	0701642*	0701651
	67°30'	4.0	60	74	82	74	0131642*	013165E
	87°30'	4.0	84	96	80	66	0711642*	0711651
200	15°	4.9	18	35	100	86	0102042*	0102051
	30°	4.9	30	49	100	86	0112042*	0112051
	45°	4.9	46	64	100	84	0702042*	0702051
	67°30'	4.9	73	88	100	86	0132042*	013205E
	87°30'	4.9	105	122	100	85	0712042*	0712051
250	15°	6.2	19	40	134	103	0102552	0102591
	30°	6.2	37	59	134	103	0112552	0112591
	45°	6.2	58	79	125	96	0122552	0122591
	87°30'	6.2	132	154	136	103	0142552	0142591
315	15°	7.7	23	52	144	120	0103052	0103091
	30°	7.7	47	74	144	118	0113052	0113091
	45°	7.7	73	100	144	118	0123052	0123091
	87°30'	7.7	166	192	144	114	0143052	0143091
400	15°	9.8	83	80	175	175	1104052	1104091
	30°	9.8	65	98	165	140	1114052	1114091
	45°	9.8	91	126	165	140	1124052	1124091
	87°30'	9.8	211	244	160	140	1144052	1144091
500	15°	12.2	150	160	160	250	-	N105091 
	30°	12.2	165	230	160	250	-	N115091 
	45°	9.8	103	152	160	150	1125052	1125091
	87°30'	9.8	380	430	160	150	1145052	1145091
630	15°	-	-	-	-	-	-	N106391 
	30°	-	-	-	-	-	-	N116391 
	45°	-	-	-	-	-	-	N126391 
	87°30'	-	-	-	-	-	-	N146391 

 Guarnizione labbro bloccata / Fixed Ring  Guarnizione labbro montata / Lip Ring  Fabbricato / Fabricated

Always chamfer cut pipe and lubricate all plain ended spigots for perfect push-fit

Curva F/F - Bend D/S

Bögen M/M - Codo H/H - Coude F/F - Bocht mof-mof

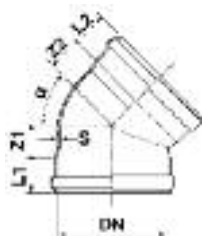

DN	α	S	Z1	Z2	L1	L2	Codice / Ref. RAL 7037 Grigio/Grey ☞ (*☞upon request)	Codice / Ref. RAL 8023 Rosso/Red ☞ (*☞upon request)
110	15°	3.2	20	20	56	56	0211342	0211341
	30°	3.2	27	27	56	56	0221342	0221341
	45°	3.2	37	37	50	50	0231142	023115E*
	87°30'	3.2	70	70	50	50	0241342	024135E*
125	45°	3.7	43	43	62	62	0231242	-
	87°30'	3.2	77	77	57	57	0241242	-
160	15°	4.0	28	28	73	73	0211642	0211641
	30°	4.0	40	40	74	74	0221642	0221641
	45°	4.0	49	49	73	73	0231642	0231641
	87°30'	4.0	124	124	78	78	0241642	0241641
200	15°	4.9	33	33	82	86	1102142	1102141
	30°	4.9	48	48	82	86	1112142	1112141
	45°	4.9	65	65	85	85	0232042	0232041
	87°30'	4.9	124	124	85	85	0242142	0242141
250	15°	6.2	64	42	101	101	1102242	1102241*
	30°	6.2	81	61	101	101	1112242	-
	45°	6.2	79	79	101	101	1232542	1232541
	87°30'	6.2	154	154	101	101	1242542	1242541
315	15°	7.7	73	52	116	116	1103342	-
	30°	7.7	88	75	116	116	1113342	-
	45°	7.7	100	100	116	116	1233042	1233041
	87°30'	7.7	192	192	116	116	1243042	1243041
400	15°	9.8	52	70	133	142	1104452*	-
	30°	9.8	80	100	133	142	1114452*	-
	45°	9.8	110	125	133	142	1234052*	1234051
	87°30'	9.8	220	245	133	142	1244052*	1244051

* Disponibile su richiesta per minimi quantitativi / Available on request for minimum order.

Curva a largo raggio 87°30' - Long radius bend 87°30'

Bögen mit weitem Halbmesser - Curva largo radio 87°30'

Coude grand rayon 87°30' - Bocht met grote radius 87°30'

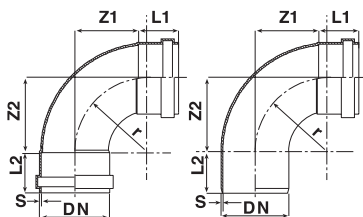

DN	Type	S	Z1	Z2	L1	L2	r	Codice / Ref. RAL 7037 Grigio/Grey ☞	Codice / Ref. RAL 8023 Rosso/Red ☞
110	M/F	3.2	106	115	58	65	142	0741142	074115E
110	F/F	3.2	106	106	58	58	142	0241142	024115E

☞ Guarnizione labbro bloccata / Fixed Ring ☞ Guarnizione labbro montata / Lip Ring

Always chamfer cut pipe and lubricate all plain ended spigots for perfect push-fit

Curva orientabile M-F - Adjustable bend

Verstellbögen - Codo orientable - Coude orientable

Verstellbare bocht

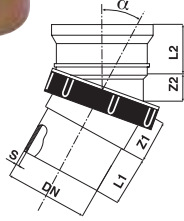

DN	α	S	Z1	Z2	L1	L2	Codice / Ref. RAL 7037 Grigio/Grey	Codice / Ref. RAL 8023 Rosso/Red
110	5°+ 30°	3.2	26	36	62	59	-	H999941

Giunto snodato 160 - Swivel 160

Kugelgelenk 150 Rotule 160 - Rótula 160 - Kogelgewicht 160



DN2	DN1	L	L1	Codice / Ref.	Note
160	160	180	85	1991658	

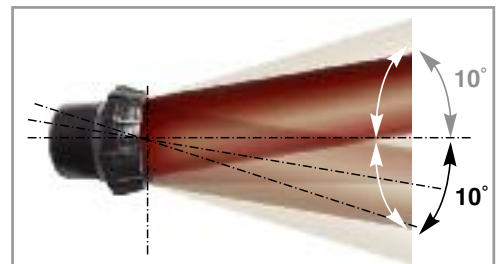
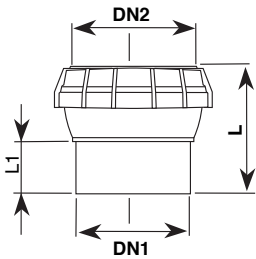

Giunto snodato per la compensazione degli assestamenti laterali

Speciale rotula di compensazione la cui sede è ottenuta dall'accoppiamento di 2 semisfere. Il prodotto viene fornito da Redi montato, prelubrificato e pronto alla posa.

La rotula consente di assorbire inclinazioni del tubo fino a +/-10°.

Installazione: adatto a sistemi O-Ring con guarnizione con possibilità di incollaggio grazie al codolo in PVC si può incollare.

Il Giunto snodato permette al tubo una rotazione di 360° con una variante di inclinazione fino a +/-10° nella tabella a fianco potrete vedere i valori a cui corrisponde espresso in cm.

Tubo lungh. 300 cm Pipe length 3 meters

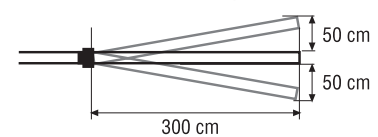

Tubo lungh. 400 cm Pipe length 4 meters

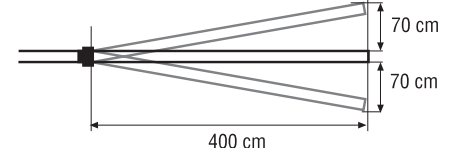

Swivel dn 160 mm.

Pre-lubricated and ready-to-install

Patent: EP 04029875,4

Rotation up to 10° to ease house connections and balance ground settlement.

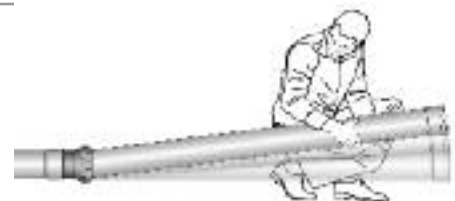

Guarnizione labbro montata / Lip Ring

Always chamfer cut pipe and lubricate all plain ended spigots for perfect push-fit



Derivazione 45° M/F - Branch 45° D/S
Abzweige 45° - Derivación 45° M/H - Embranchement 45° M/F
T-Stuk 45° mof-spie

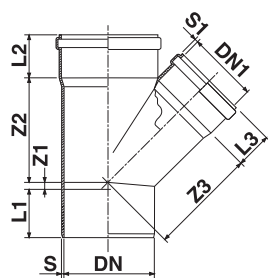



DN	DN1	S	S1	Z1	Z2	Z3	L1	L2	L3	Codice / Ref. RAL 7037 Grigio/Grey (*)	Codice / Ref. RAL 8023 Rosso/Red
110	110	3.2	-	25	140	140	60	50	50	0301142*	0301151
125	110	3.2	3.2	19	147	152	69	62	56	0319242*	0319251
125	125	3.2	-	25	160	160	70	64	64	0801242*	080125E
160	110	4.0	3.2	2	168	176	82	74	56	0311642*	0311651
160	125	4.0	3.2	12	180	185	83	74	62	0313642*	0313651
160	160	4.0	-	38	205	205	83	71	71	0301642*	0301651
200	110	4.9	3.2	17	191	200	100	86	56	0313542*	0313551
200	125	4.9	3.2	7	201	212	100	86	62	0313742*	0313751
200	160	4.9	4.0	18	228	232	100	86	74	0312042*	0312051
200	200	4.9	-	45	256	256	100	81	81	0302042*	0302051
250	110	6.2	3.2	-47	251	271	175	103	56	0313352	0313391
250	125	6.2	3.2	-27	217	236	196	98	56	-	D313491
250	160	6.2	4.0	3	250	261	131	103	74	0314052	0314091
250	200	6.2	4.9	24	275	280	134	103	86	0314152	0314191
250	250	6.2	-	57	311	311	134	101	101	0302552	0302591
315	110	7.7	3.2	-79	287	315	190	117	55	1318052	1318051
315	125	7.7	3.2	-69	287	310	180	117	62	1318152	1318151
315	160	7.7	4.0	33	289	306	144	114	75	0314252	0314291
315	200	7.7	4.9	5	317	337	144	114	85	0314352	0314391
315	250	7.7	6.2	28	335	344	156	114	99	D314452	D314491
315	315	7.7	-	73	392	392	144	114	114	1303052	1303091
400	110	9.8	3.2	-130	450	435	165	170	65	1314452	1314451 ▲
400	125	9.8	3.2	-20	430	380	175	145	65	1313352	1313351 ▲
400	160	9.8	4.0	69	319	385	165	170	95	1316652	1316651 ▲
400	200	9.8	4.9	50	355	435	165	180	105	1317752	1317751 ▲
400	250	9.8	6.2	35	440	445	165	180	130	-	D314691 ◆
400	315	9.8	6.9	73	480	530	160	170	135	-	D314791 ◆
400	400	9.8	-	170	510	535	165	175	170	-	N304091 ◆
500	110	10.5	3.2	-185	360	420	180	250	65	1315052*	1315051 ▲
500	125	10.5	3.2	-55	510	457	165	170	65	1315252*	1315251* ▲
500	160	10.5	4.0	-65	450	680	200	250	90	1315352*	1315351 ▲
500	200	10.5	4.9	87	400	575	200	250	110	1315452*	1315451 ▲
500	250	12.3	6.2	-10	510	530	200	250	110	-	D314991 ◆
500	315	12.3	6.9	-45	475	503	200	250	135	-	D315091 ◆
500	400	12.3	9.8	115	615	640	200	250	180	-	D315191 ◆
500	500	12.3	-	240	665	675	200	250	255	-	N305091 ◆

* Disponibile su richiesta per minimi quantitativi / Available on request for minimum order.

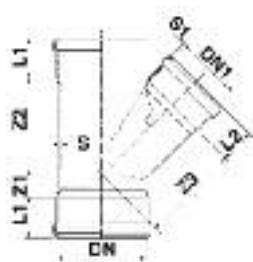

Guarnizione labbro bloccata / Fixed Ring Guarnizione labbro montata / Lip Ring ◆ Fabbriato / Fabricated ▲ Termoformato / Thermoformed
Always chamfer cut pipe and lubricate all plain ended spigots for perfect push-fit

Derivazione 45° F/F - Branch 45° T/S
Abzweige 45°M/M - Derivación 45° H/H
Embranchement 45° F/F - T-Stuk 45° 3 X mof



DN	DN1	S	S1	Z1	Z2	Z3	L1	L3	Codice / Ref. RAL 7037 Grigio/Grey	Codice / Ref. RAL 8023 Rosso/Red (*  )
110	110	3.2	3.2	37	137	137	60	60	0441142	0441141
125	125	3.2	3.2	44	160	160	64	64	0441242	0441241
160	110	4.0	3.2	19	169	176	73	56	0311742	0311741
160	125	4.0	3.2	41	180	185	74	62	0311832	-
160	160	4.0	-	52	203	203	72	72	0441642	0441641
200	110	4.9	3.2	5	179	195	86	62	1443142	1443142*
200	125	5.9	3.7	54	228	232	86	74	0313832	-
200	160	5.9	4.7	54	228	232	86	74	0312132	0312151*
200	200	4.9	4.9	66	256	256	181	81	1442042	1442041
250	160	6.2	4.0	41	251	262	101	74	1444042	1444041
250	200	6.2	4.9	68	278	302	101	86	1444142	1444141
250	250	6.2	6.2	101	311	311	101	101	1442542	1442551*
315	110	7.7	3.2	7	287	315	117	55	1443442	1443451*
315	125	7.7	3.2	7	287	310	117	68	1443542	1443542* ▲
315	160	7.7	4.0	7	287	305	117	74	1444242	1444241
315	200	7.7	4.9	35	317	338	117	86	1444342	-
315	250								1444551	-
315	315	7.7	7.7	113	392	392	117	117	1443042	1443041
400	110	9.8	3.2	30	450	380	145	60	1444442*	1444441 ▲
400	160	9.8	3.2	30	450	410	145	90	1446642	1446641* ▲
400	200	9.8	3.2	30	450	430	145	100	1447742	1447741* ▲
500	110	10.5	3.2	-185	360	420	180	250	1445142*	1445141* ▲
500	125	10.5	3.2	-55	510	475	165	170	1445242*	1445241* ▲
500	160	10.5	4.0	-65	450	680	200	250	1445342*	1445341* ▲
500	200	10.5	4.9	87	400	575	200	250	1445442	1445441* ▲

* Disponibile su richiesta per minimi quantitativi / Available on request for minimum order.

 Guarnizione labbro bloccata / Fixed Ring  Guarnizione labbro montata / Lip Ring ▲ Termoformato / Thermoformed

Always chamfer cut pipe and lubricate all plain ended spigots for perfect push-fit

Derivazione 87°30' M/F - Tee 87°30' D/S
Abzweige 87°30' - Derivación 87°30' M/H
Embranchement 87°30' M/F - T-Stuk 87°30' mof-spie

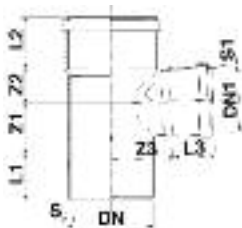

DN	DN1	S	S1	Z1	Z2	Z3	L1	L2	L3	Codice / Ref. RAL 7037 Grigio/Grey (* 🔧)	Codice / Ref. RAL 8023 Rosso/Red (🔧)
110	110	3.2	3.2	55	69	69	60	50	50	0341142*	0341151
125	110	3.2	3.0	84	58	92	78	77	67	0357242*	0357251
125	125	3.2	3.2	66	70	78	62	62	62	0811242*	0811251
160	110	4.0	3.2	59	69	87	81	74	57	0351642*	035165E
160	125	4.0	3.2	60	81	94	88	71	62	0353642*	0353651
160	160	4.0	-	76	98	98	88	74	74	0811642*	0811651
200	110	4.9	3.2	50	110	120	135	86	59	0350142	035015E
200	125	4.9	3.2	58	110	120	125	86	62	0350242	035025E
200	160	4.9	4.0	75	110	132	110	86	74	0352042	0352051
200	200	4.9	-	105	119	119	100	86	86	0812042*	081205E
250	110	6.2	3.2	90	100	132	144	99	51	0353542	0353551
250	125	6.2	3.2	90	100	132	113	130	61	0353442	0353451
250	160	6.2	4.0	90	100	134	117	126	85	0354042	0354051
250	200	6.2	4.9	132	143	136	123	120	116	0353842	0353851
250	250	6.2	-	120	152	152	135	101	101	0342552	0342591
315	110	7.7	3.2	50	150	176	180	116	56	1352252	1352251
315	125	7.7	3.2	55	150	176	174	116	65	1353352	1353351
315	160	7.7	4.0	75	150	180	155	116	73	1354452	1354451
315	200	7.7	4.9	95	150	185	135	116	87	1355552	1355551
315	250	7.7	6.2	166	178	174	128	140	110	D354652	D354691
315	315	7.7	7.7	166	185	174	146	114	114	1343052	1343091
400	110	9.8	3.2	153	183	240	180	145	60	1354152*	1354151 ▲
400	125	9.8	3.2	153	183	240	180	145	65	1354252*	1354251* ▲
400	160	9.8	4.0	120	205	135	215	160	87	1356652*	1356651 ▲
400	200	9.8	4.9	145	240	145	215	175	104	1357752*	1357751 ▲
400	250	9.8	6.2	186	227	270	180	145	105	1358852*	1358851 ▲
400	315	9.8	6.9	186	227	260	180	145	125	1359952*	1359951 ▲
400	400	9.8	9.8	250	270	230	215	175	175	1344052	1344051 ▲
500	110	10.5	3.2	163	205	290	210	170	60	1355052*	1355051* ▲
500	125	10.5	3.2	163	205	290	210	170	65	1355252*	1355251* ▲
500	160	10.5	4.0	163	205	300	210	170	85	1355352	1355351 ▲
500	200	10.5	4.9	163	205	300	210	170	95	1355452	1355451 ▲
500	250	10.5	6.2	-	-	-	210	170	105	-	D354991 ✦
500	315	10.5	6.9	-	-	-	210	170	125	-	D355091 ✦
500	400	10.5	9.8	-	-	-	210	170	145	-	D355191 ✦
500	500	12.3	12.3	265	355	345	295	245	245	-	N345091 ✦
630	630	-	-	-	-	-	-	-	-	-	N346391* ✦

* Disponibile su richiesta per minimi quantitativi / Available on request for minimum order.

🔧 Guarnizione labbro bloccata / Fixed Ring 🔧 Guarnizione labbro montata / Lip Ring ✦ Fabricato / Fabricated ▲ Termoformato / Thermoformed
 Always chamfer cut pipe and lubricate all plain ended spigots for perfect push-fit



Derivazione 87°30' F/F - Tee 87°30' T/S
Abzweige 87°30' M/M - Derivación 87°30' H/H
Embranchement 87°30' F/F - T-Stuk 87°30' 3 x mof



DN	DN1	S	S1	Z1	Z2	Z3	L1	L3	Codice / Ref. RAL 7037 Grigio/Grey	Codice / Ref. RAL 8023 Rosso/Red
125	125	3.2	3.2	83	78	78	62	62	0451242	0451241
160	110	4.0	3.2	70	75	95	72	56	0351742	0351741
160	125	4.0	3.2	85	81	94	72	62	0463642	0463641
160	160	4.0	4.0	95	99	99	72	72	0451642	0451641
200	110	4.9	3.2	108	110	120	86	60	0460142	0460141
200	125	4.9	3.2	108	110	120	86	62	0460242	0460241
200	160	4.9	4.0	108	110	132	86	74	0460642	0460641
200	200	4.9	4.9	120	120	120	86	86	1452042	1452041
250	110	6.2	3.2	60	135	145	105	56	1461142*	1461141
250	125	6.2	3.2	100	100	132	103	130	1461242	1461241
250	160	6.2	4.0	100	100	134	107	126	1461642	1461651*
250	200	6.2	4.9	100	143	136	113	120	1462042	1462051*
250	250	6.2	6.2	165	152	152	101	101	1452542	1452541
315	110	7.7	3.2	150	150	176	116	56	1464142	1464141
315	125	7.7	3.2	150	150	176	116	65	1464342	1464341
315	160	7.7	4.0	150	150	180	116	73	1464242	1464251
315	200	7.7	4.9	150	150	185	116	87	1464442	1464451
315	315	7.7	7.7	211	185	185	117	117	1453042	1453041
400	110	9.8	3.2	192	192	240	145	60	1465542	1465541 ▲
400	160	9.8	4.0	192	192	250	145	85	1466642	1466641 ▲
400	125	9.8	3.2	192	192	240	145	65	1463342*	1463341* ▲
400	200	9.8	4.9	192	192	250	145	95	1467742	1467741 ▲
400	250	9.8	6.2	227	227	270	145	105	1468842	1468841 ▲
400	315	9.8	7.7	227	227	260	145	125	1469942	1469941* ▲
400	400	9.8	9.8	250	270	230	175	175	1454052	1454051 ▲
500	110	10.5	3.2	163	205	290	210	170	1465042*	1465041* ▲
500	125	10.5	3.2	163	205	290	210	170	1465142*	1465141* ▲
500	160	10.5	4.0	163	205	300	210	170	1465242*	1465241* ▲
500	200	10.5	4.9	163	205	300	210	170	1465342	1465341* ▲

* Disponibile su richiesta per minimi quantitativi / Available on request for minimum order.

🔒 Guarnizione labbro bloccata / Fixed Ring 🗑️ Guarnizione labbro montata / Lip Ring ▲ Termoformato / Thermoformed

Always chamfer cut pipe and lubricate all plain ended spigots for perfect push-fit



Derivazione a largo raggio 87°30' - Long radius tee 87° 30'

DN	Type	S	S1	Z2	L1	L2	L3	Codice / Ref. RAL 7037 Grigio/Grey	Codice / Ref. RAL 8023 Rosso/Red
110	F/F	3.2	2.9	146	62	57.5	57.5	0451342	045135E
110	M/F	3.2	2.9	146	62	57.5	57.5	0891342	089135E

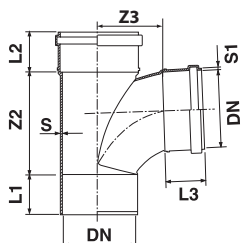

Guarnizione labbro bloccata / Fixed Ring Guarnizione labbro montata / Lip Ring

Derivazione doppia 45° - Double branch 45°
 Doppelabzweige 45° - Derivación doble 45°
 Culotte double 45° - Dubbel T-Stuk 45° 3 x mof-spie



DN	S	Z1	Z2	L	L1	Codice / Ref. RAL 7037 Grigio/Grey	Codice / Ref. RAL 8023 Rosso/Red
110	3.2	30	141	57	60	0361142	0361141
125	3.2	30	157	64	65	0361242	-
160	4.0	51	204	85	88	0361642	-

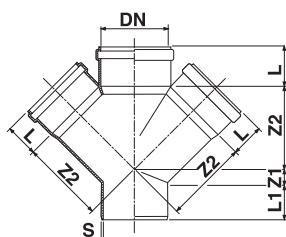

Guarnizione labbro bloccata / Fixed Ring

Derivazione doppia 87°30' - Double branch 87°30'
 Doppelabzweige 87°30' - Derivación doble 87°30'
 Culotte double 87°30' - Dubbel T-Stuk 87°30' 3 x mof-spie



DN	α	S	Z1	Z2	L	L1	Codice / Ref. RAL 7037 Grigio/Grey	Codice / Ref. RAL 8023 Rosso/Red
110	87°30'	3.2	62	70	70	80	0381142	-

Guarnizione labbro bloccata / Fixed Ring



Always chamfer cut pipe and lubricate all plain ended spigots for perfect push-fit



Derivazione con tappo - Access pipe
 Reinigungsrohr - Té de registro - Té de visite
 Ontstoppingsstuk met schroefdeksel

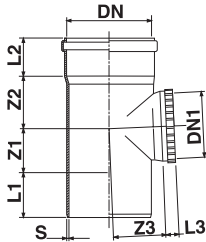

DN	DN1	S	Z1	Z2	Z3	L1	L2	L3	Codice / Ref. RAL 7037 Grigio/Grey (*)	Codice / Ref. RAL 8023 Rosso/Red
110	110	3.0	59	69	69	60	55	36	1821142*	1821151
125	125	3.2	66	70	78	62	62	22	1821242*	1821251
160	160	4.0	83	99	99	85	72	24	1821642*	1821651
200	200	4.9	105	119	119	100	86	28	1822042*	1822051
250	250	6.2	120	152	152	135	101	70	1402552	1402591
315	315	7.7	166	185	185	146	114	90	1403052	1403091
400	315	9.8	227	227	260	180	145	30	1404352*	1404351 ▲

* Disponibile su richiesta per minimi quantitativi / Available on request for minimum order.

Guarnizione labbro bloccata / Fixed Ring Guarnizione labbro montata / Lip Ring ▲ Termoformato / Thermoformed

Camera di ispezione - Access chamber
 Reinigungsrohre - Inspección lineal - Inspection linéaire
 Inspektiestuk

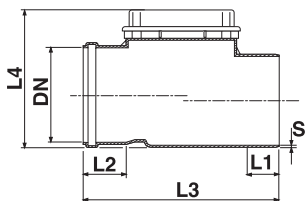

DN	S	L1	L2	L3	L4	Codice / Ref. RAL 7037 Grigio/Grey	Codice / Ref. RAL 8023 Rosso/Red
110	4.0	61	61	307	192	-	1475551
125	4.0	68	65	318	192	-	1476051
160	4.0	74	74	334	220	-	1471691
200	4.5	100	86	451	280	-	1472091

Guarnizione labbro montata / Lip Ring

Always chamfer cut pipe and lubricate all plain ended spigots for perfect push-fit

Tappo a vite maschio - Access plug
 Schraubverschluß mit Dichtung - Tapón de registro
 Tampon de visite - Eindstuk met schroefdeksel - spie

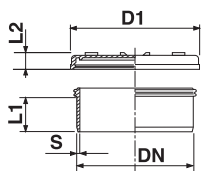

DN	D1	S	L1	L2	Codice / Ref. RAL 7037 Grigio/Grey	Codice / Ref. RAL 8023 Rosso/Red
110	125	3.4	62	19	0651102	0651101
125	141	3.0	60	25	0651202	0651201
160	176	3.1	60	23	1651602	1651601
200	216	3.4	80	23	1652002	1652001

Guarnizione labbro montata / Lip Ring

Tappo a baionetta maschio - Access plug
 Bajonettverschluß mit Dichtung - Tapón de registro
 Tampon à baïonette M - Eindstuk met schroefdeksel-spie

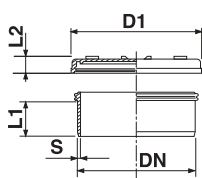

DN	D1	S	L1	L2	Codice / Ref. RAL 7037 Grigio/Grey	Codice / Ref. RAL 8023 Rosso/Red
250	262	6.1	90	18	1652502	1652501
315	354	7.7	93	22	1653002	1653001

Guarnizione labbro montata / Lip Ring

Tappo a baionetta femmina - Access plug female
 Kappe mit Bajonettverschluß und Dichtung
 Tapón de registro hembra - Tampon à baïonnette F
 Eindstuk met schroefdeksel-mof

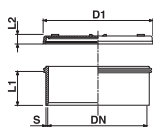

DN	D1	S	L1	L2	Codice / Ref. RAL 7037 Grigio/Grey	Codice / Ref. RAL 8023 Rosso/Red
250	262	5.5	86	18	16525F2	
315	330	6.9	89	22	16530F2	

Guarnizione labbro montata / Lip Ring

Always chamfer cut pipe and lubricate all plain ended spigots for perfect push-fit

Tappo di chiusura maschio - *Socket plug*
Muffenstopfen - *Tapón ciego*
Bouchon de fermeture - *Eindkap spie mof-spie*

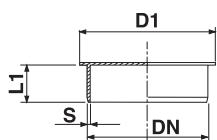

DN	D1	S	L1	Codice / Ref. RAL 7037 Grigio/Grey	Codice / Ref. RAL 8023 Rosso/Red
110	126	3.2	38	0661102	0661101
125	142	3.2	42	0661202	0661201
160	180	4.0	49	0661602	0661601
200	223	4.9	59	0662002	0662001
250	282	6.2	90	0662502	0662501
315	350	7.7	93	0663002	0663001
400	440	9.8	95	06640M2	06640M1
500	558	12.3	120	-	D665001 ◆

◆ *Fabbricato / Fabricated*

Tappo di chiusura femmina - *End cap*
Kappe - *Tapón hembra* - *Bouchon femelle* - *Afsluitkap*

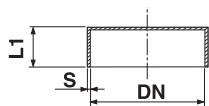

DN	S	L1	Codice / Ref. RAL 7037 Grigio/Grey	Codice / Ref. RAL 8023 Rosso/Red
110	2.0	32	06613F2	06613F1
125	2.5	32	06615F2	06615F1
160	2.7	35	06617F2	06617F1
200	2.9	35	06621F2	06621F1
250	3.5	40	06628F2	06628F1
315	4.0	52	06634F2	06634F1
400	6.0	95	06640F2	06640F1

Always chamfer cut pipe and lubricate all plain ended spigots for perfect push-fit

Aumento conico eccentrico - *Invert reducer*
Übergangsrohr - Reducción excéntrica
Réduction excentrée - Verloopstuk excentrisch

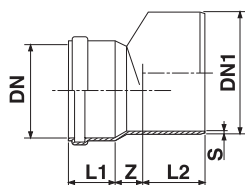

DN	DN1	S	Z	L1	L2	Codice / Ref. RAL 7037 Grigio/Grey (*)	Codice / Ref. RAL 8023 Rosso/Red
110	125	3.2	22	56	63	0513242*	0513251
110	160	4.0	43	56	82	0511642*	0511651
125	160	4.0	36	62	82	0513642*	0513651
125	200	4.9	53	62	100	0512042*	0512051
160	200	4.9	39	74	100	0514042*	0514051
160	250	6,2	66	73	125	0514642	0514651
200	250	6.2	39	96	134	0512542*	051255E
200	315	7.7	85	86	145	0513342*	051335E
250	315	7.7	64	103	144	0513052	0513091
315	400	9.8	88	118	156	0519252	0519291

Aumento conico concentrico - *Invert reducer*

400	500	-	-	-	-	-	D519491
-----	-----	---	---	---	---	---	---------

NB: other larger diameters available upon request / diamètres supérieurs disponibles sur demande.

Guarnizione labbro bloccata / Fixed Ring Guarnizione labbro montata / Lip Ring

Aumento piatto eccentrico - *Flat invert reducer*
Übergangsrohr - Reducción - Réduction excentrée
Verloopstuk excentrisch-kort

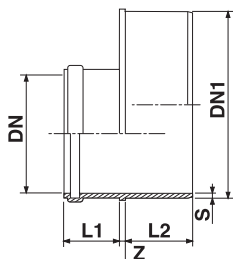

DN	DN1	S	Z	L1	L2	Codice / Ref. RAL 7037 Grigio/Grey (*)	Codice / Ref. RAL 8023 Rosso/Red
110	200	4,6	40	60	59	1533542	1533551 ♦
110	250	6.1	7	56	90	0534142*	0534151
110	315	7.7	40	60	93	1534042	1534051 ♦
110	400	6.0	40	60	95	1535042	1535051 ♦
125	250	6.1	7	62	90	0534242*	0534251
125	315	7.7	40	65	93	1534342**	1534351 ♦
125	400	6.0	40	65	95	1535542**	1535551** ♦
160	315	7.7	7	74	93	0534842*	0534851
160	400	6.0	50	85	95	1536042	1536051 ♦
200	400	6.0	50	95	95	1536542	1536551 ♦
250	400	6.0	50	105	95	1537052	1537091 ♦

* Disponibile su richiesta per minimi quantitativi / Available on request for minimum order.

Guarnizione labbro bloccata / Fixed Ring Guarnizione labbro montata / Lip Ring

Always chamfer cut pipe and lubricate all plain ended spigots for perfect push-fit

Always chamfer cut pipe and lubricate all plain ended spigots for perfect push-fit

Collegamento Gres/PVC - Clay/PVC adaptor

Anschlußstück an Steinzeugrohr - Adaptador Gres/Pvc

Passage Grès/Pvc - Overgangsstuk Gres/PVC

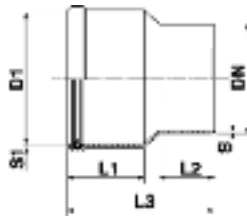

DN	D1	S	S1	L1	L2	L3	Codice / Ref. RAL 7037 Grigio/Grey	Codice / Ref. RAL 8023 Rosso/Red
110	136	3.0	3.0	89	60	170	0621192	0621191
125	160	3.4	3.0	98	67	190	0621292	0621291
160	190	4.0	3.6	112	81	215	0621692	0621691
200	242	5.5	4.5	125	100	255	0622092	0622091

Guarnizione labbro montata / Lip Ring



Collegamento PVC/Gres - Pvc/Clay adaptor

Anschlußstück an Steinzeugrohr/Muffe - Adaptador Pvc/Gres

Passage Pvc/Grès - Overgangsstuk Pvc/Gres

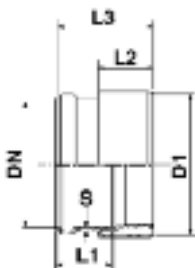

DN	D1	S	L1	L2	L3	Codice / Ref. RAL 7037 Grigio/Grey	Codice / Ref. RAL 8023 Rosso/Red
110	136	3.0	56	70	114	-	0621091
125	160	3.0	62	70	119	-	0621391
160	190	3.6	72	70	123	-	0621791
200	242	-	-	-	-	-	D622191

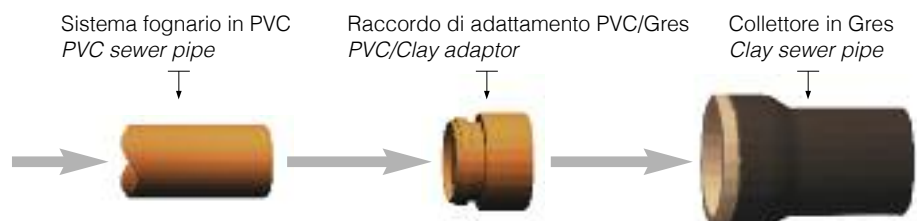

Guarnizione labbro montata / Lip Ring



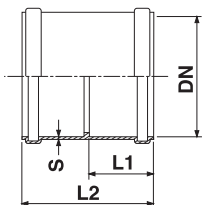

Always chamfer cut pipe and lubricate all plain ended spigots for perfect push-fit

Manicotto con battente - *Double socket*
Doppelmuffen - *Manguito de union con tope*
Manchon avec arrêt - *Steekmof*





DN	S	L1	L2	Codice / Ref. RAL 7037 Grigio/Grey (*  )	Codice / Ref. RAL 8023 Rosso/Red 
110	2.9	60	122	0631142*	0631151
125	2.9	68	141	0631242*	0631251
160	3.6	75	151	0631642*	063165E
200	4.4	106	217	0632042*	063205E
250	5.5	123	254	0632552	0632591
315	6.9	144	297	0633052	0633091
400	8.8	160	325	0634052	0634091
500	9.8	170	440	1635052	1635051 ▲

 Guarnizione labbro bloccata / Fixed Ring  Guarnizione labbro montata / Lip Ring ▲ Termoformato / Thermoformed

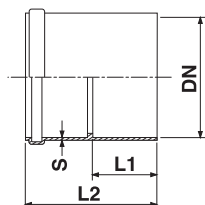
Manicotto con battente 1 O-Ring - *Single socket*
Aufklebemuffe - *Manguito mixto (1 x junta / 1 x pegar)*
Manchon mixte - *Steekmof manchet x lijmmof*



DN	S	L1	L2	Codice / Ref. RAL 7037 Grigio/Grey (*  )	Codice / Ref. RAL 8023 Rosso/Red 
110	2.9	60	122	0631182	0631181
125	2.9	68	141	0631282	0631281
160	3.6	75	154	0631682	0631681
200	4.4	106	217	0632082	0632081
250	5.5	123	254	0632582	0632581
315	6.9	144	297	0633082*	0633081



* Disponibile su richiesta per minimi quantitativi / Available on request for minimum order.

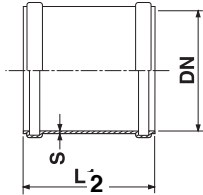

 Guarnizione labbro bloccata / Fixed Ring  Guarnizione labbro montata / Lip Ring

Always chamfer cut pipe and lubricate all plain ended spigots for perfect push-fit

Manicotto senza battente - *Repair/Slip coupler*
Überschiebmuffen - *Manguito deslizando*
Manchon coulissant - *Overschuifmof*





DN	S	L2	Codice / Ref. RAL 7037 Grigio/Grey (* ) 	Codice / Ref. RAL 8023 Rosso/Red 
110	2.9	122	0611142*	0611151
125	2.9	141	0611242*	061125E
160	3.6	151	0611642*	0611651
200	4.4	217	0612042*	0612051
250	5.5	254	0612552	0612591
315	6.9	297	0613052	0613091
400	8.8	325	0614052	0614091
500	9.8	440	1615052	1615051 ▲
630	-	-	-	D616391

 Guarnizione labbro bloccata / Fixed Ring  Guarnizione labbro montata / Lip Ring ▲ Termoformato / Thermoformed

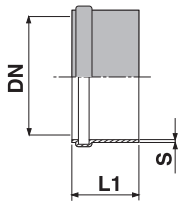
Manicotto sabbato e di passaggio - *Sanded protection sleeve*
Muffe besandet - *Manguito pasamuro*
Accès de regard sablé court - *Instortmof met zandhechting*



DN	S	L1	Type	Codice / Ref. Sabbato / Sanded 	Codice / Ref. RAL 8023 Rosso/Red 
110	2.9	61	A	0641191	-
125	2.9	69	A	0641291	-
160	3.6	74	A	0641642	-
200	4.4	107	A	0642042	-
250	5.5	126	A	0642591	-
315	6.9	146	A	0643091	-
400	8.8	160	A	1644091	-
500	9.8	214	A	1645091	-
160	3.6	110	B	-	B641751
200	4.4	110	B	-	B642151

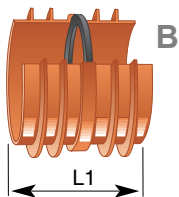

 Guarnizione labbro montata / Lip Ring

Always chamfer cut pipe and lubricate all plain ended spigots for perfect push-fit

Sifone A-N (O-Ring) - REDI trap interceptor
Sifon mit Reinigungsverschlüssen - Sifón con registros
Syphon à 2 regards - Riolsifon met ontstopping

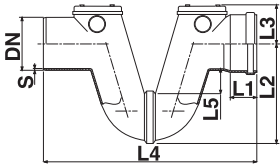

DN	DN1	S	L1	L2	L3	L4	L5	L6	Codice / Ref. RAL 7037 Grigio/Grey (* 🔴) 🔲	Codice / Ref. RAL 8023 Rosso/Red 🔲
110	40	3.0	61	202	88	495	35	153	1750052	1750091
125	40	3.0	62	235	92	490	38	175	1751352	1751391

🔲 Guarnizione labbro bloccata / Fixed Ring 🔲 Guarnizione labbro montata / Lip Ring

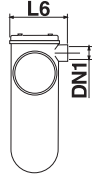

Sifone A-N (O-Ring) - REDI trap interceptor
Sifon mit Reinigungsverschlüssen - Sifón con registros
Syphon à 2 regards - Riolsifon met ontstopping

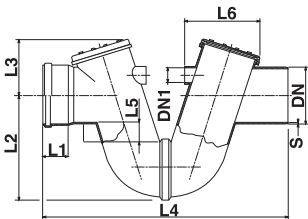

DN	DN1	S	L1	L2	L3	L4	L5	L6	Codice / Ref. RAL 7037 Grigio/Grey (* 🔴) 🔲	Codice / Ref. RAL 8023 Rosso/Red 🔲
160	63	3.0	72	295	158	655	50	210	1751652	1751691
200	63	4.0	84	345	198	795	50	270	1752052	1752091

🔲 Guarnizione labbro bloccata / Fixed Ring 🔲 Guarnizione labbro montata / Lip Ring

Sifone P (O-Ring) - Universal Gully trap



DN	H	L	Z1	Z2	Materiale	Codice / Ref. RAL 7037 Grigio/Grey	Codice / Ref. RAL 8023 Rosso/Red 🔲
110	142	310	225	50*	PP	-	Z7713PP

* Battuta sifonante 50 mm (quando installata con curva 45°) / Siphon 50mm (when fitted with 45° bend)

🔲 Guarnizione labbro montata / Lip Ring

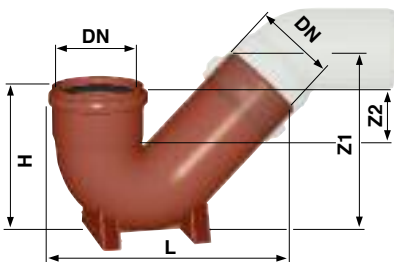

Always chamfer cut pipe and lubricate all plain ended spigots for perfect push-fit



Le Valvole Antiriflusso REDI DN 100 ÷ 200 sono conformi alla normativa EN 13564 e certificate dall'Istituto LGA.

Valvole Certificate garantiscono le seguenti prestazioni:

- Deflusso regolare e garantito dall'apertura del piattello anche in presenza di minime pressioni (50 mm di colonna d'acqua pari a 0,005 bar).
- Indefornabilità e resistenza del prodotto dopo 600 cicli di prova a temperatura variabile (60 secondi a 75°C / 60 secondi a 15°C).
- Efficacia del dispositivo antiriflusso sottoposto a 35 cicli di riflusso con durata variabile da 5 a 10 minuti e pressione da 0,01 a 0,5 bar (pari a 5 metri di colonna d'acqua).
- Resistenza e tenuta idraulica di tutto il corpo valvola sottoposto a una pressione di 5 metri di colonna d'acqua pari a 0,5 bar.
- Conformità degli attacchi alle dimensioni stabilite dalle norme EN 1401 e EN 1329.
- Dimensionamento e libero azionamento ottimali delle parti mobili per evitare il rischio di inceppamenti durante i movimenti di apertura/chiusura.

Redi anti-flooding valves DN 100 ÷ 200 are certified by German Institute LGA and kitemarked LGA.

Certified anti-flooding valves grant the following performances:

- Regular flow granted by the opening of the flap also in presence of minimum pressure rates (0.005 bar).
- Non-deformability and tightness of the product after 600 test cycles at variable temperature (60 seconds at 75° / 60 seconds at 15°).
- Effectiveness of Redi anti-flooding device after 35 cycles of backflow of variable duration from 5 up to 10 minutes and pressure rate from 0,01 up to 0.5 bar.
- Water tightness of the entire valve's body, subjected to a pressure rate of 0.5 bar.
- Inlet and outlet of the valves are in accordance with EN 1401 and EN 1329.



Le valvole antiriflusso REDI DN 100÷200 sono contraddistinte dal marchio **CE**
*REDI anti-flooding valves DN 100÷200 are characterized by the presence of **CE** marking.*

EN 13564



Valvola antiriflusso - Non-return valve
Rückstauverschluss - Válvula anti-retorno - Clapet anti-retour
Ontstoppingsstuk met keerklep en vergrendeling

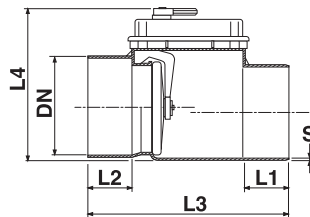
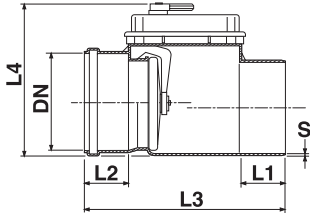

DN	S	L1	L2	L3	L4	Codice / Ref. RAL 8023 Rosso/Red	Note
100	4.0	58	56	300	230	1555052*	*Colore: Grigio/Grey Con guarnizione a labbro / With Lip-ring
110	4.0	61	61	307	230	1555551	Con guarnizione a labbro / With Lip-ring
125	4.0	68	65	318	230	1556051	Con guarnizione a labbro / With Lip-ring
160	4.0	74	74	337	255	1551691	Con guarnizione a labbro / With Lip-ring
200	4.5	100	86	451	300	1552091	Con guarnizione a labbro / With Lip-ring

100	4.0	58	56	300	230	1555001	Bicchiere a incollaggio / Solvent socket
110	4.0	61	61	307	230	1555501	Bicchiere a incollaggio / Solvent socket
125	4.0	68	65	318	230	1556001	Bicchiere a incollaggio / Solvent socket
140	4.0	69	65	325	255	1551401	Bicchiere a incollaggio / Solvent socket
160	4.0	74	74	337	255	1551601	Bicchiere a incollaggio / Solvent socket
200	4.5	100	86	451	300	1552001	Bicchiere a incollaggio / Solvent socket

Guarnizione labbro montata / Lip Ring

**INOX
FLAP**



Valvola antiriflusso piattello Inox - Non-return valve
Rückstauverschluss - Válvula anti-retorno - Clapet anti-retour
Ontstoppingsstuk met keerklep en vergrendeling

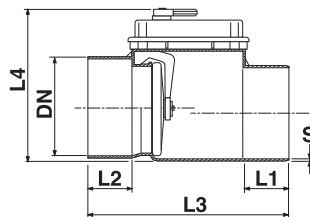
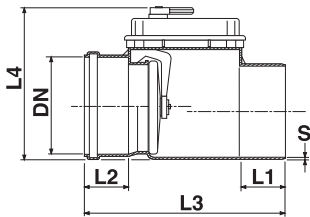

DN	S	L1	L2	L3	L4	Codice / Ref. RAL 8023 Rosso/Red	Note
110	4.0	61	61	307	230	1555651	Con guarnizione a labbro / With Lip-ring
125	4.0	68	65	318	230	1556151	Con guarnizione a labbro / With Lip-ring
160	4.0	74	74	337	255	1551791	Con guarnizione a labbro / With Lip-ring

100	4.0	61	57	300	230	1555101	Bicchiere a incollaggio / Solvent socket
110	4.0	61	61	307	230	1555601	Bicchiere a incollaggio / Solvent socket
125	4.0	68	65	318	230	1556101	Bicchiere a incollaggio / Solvent socket
140	4.0	69	65	325	255	1551501	Bicchiere a incollaggio / Solvent socket
160	4.0	74	74	337	255	1551701	Bicchiere a incollaggio / Solvent socket

Guarnizione labbro montata / Lip Ring



Always chamfer cut pipe and lubricate all plain ended spigots for perfect push-fit

Valvola antiriflusso - Non-return valve
Rückstauverschluss - Válvula anti-retorno - Clapet anti-retour
Ontstoppingsstuk met keerklep en vergrendeling

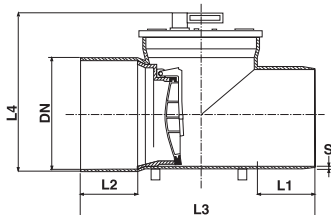
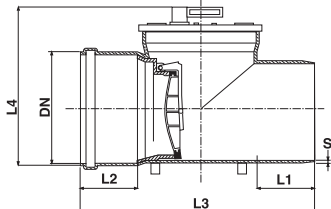

DN	S	L1	L2	L3	L4	Codice / Ref. RAL 8023 Rosso/Red	Note
250	6.2	130	102	520	374	1552591	Con guarnizione a labbro / With Lip-ring
315	7.7	160	125	615	440	1553091	Con guarnizione a labbro / With Lip-ring
400	9.8	245	140	800	480	1554091	Con guarnizione a labbro / With Lip-ring Senza leva di blocco Without emergency closure device
250	6.2	130	102	520	374	1552501	Bicchiera a incollaggio / Solvent socket
315	7.7	160	125	615	440	1553001	Bicchiera a incollaggio / Solvent socket

☛ Guarnizione labbro montata / Lip Ring

Valvola antiriflusso - Non-return valve
Rückstauverschluss - Válvula anti-retorno - Clapet anti-retour
Ontstoppingsstuk met keerklep en vergrendeling

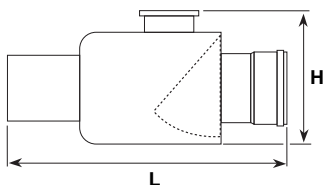

DN	H	L	Codice / Ref. RAL 8023 Rosso/Red	Note
500	750	1400	T555191	SN2 ◆ Con guarnizione a labbro / With Lip-ring
630	1100	1700	T556391	SN2 ◆ Con guarnizione a labbro / With Lip-ring

☛ Guarnizione labbro montata / Lip Ring ◆ Fabbriato / Fabricated

Always chamfer cut pipe and lubricate all plain ended spigots for perfect push-fit



Valvola Clapet Femmina di fine linea *Flap valve*

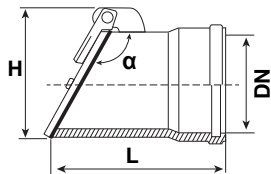

DN (mm)	L (mm)	H (mm)	α	Codice / Ref.	Note
110	160	155	11°	P5510F1	
125	160	170	11°	P5512F1	
160	180	205	11°	P5516F1	
200	200	245	11°	P5520F1	
250	275	305	11°	P5525F1	
315	330	370	11°	P5530F1	
400	350	450	11°	P5540F1	
500	380	550	11°	P5550F1	
630	440	685	11°	P5563F1	



Valvola Clapet Maschio di fine linea *Flap valve*

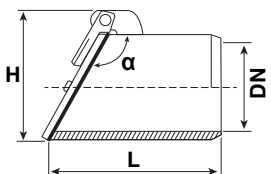

DN (mm)	L (mm)	H (mm)	α	Codice / Ref.	Note
110	160	155	11°	P5510M1	
125	160	170	11°	P5512M1	
160	180	205	11°	P5516M1	
200	200	245	11°	P5520M1	
250	275	305	11°	P5525M1	
315	330	370	11°	P5530M1	
400	350	450	11°	P5540M1	
500	380	550	11°	P5550M1	
630	440	685	11°	P5563M1	



Valvola Clapet *Flap valve*

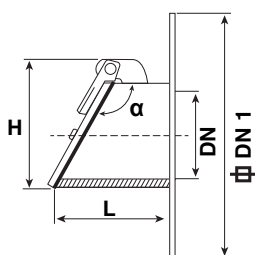

DN (mm)	DN1 Φ	L (mm)	H (mm)	α	Codice / Ref.	Note
110	160	110	155	11°	P551001	
125	160	110	170	11°	P551201	
160	210	120	205	11°	P551601	
200	250	150	245	11°	P552001	
250	320	210	305	11°	P552501	
315	370	260	370	11°	P553001	
400	480	290	450	11°	P554001	
500	600	330	550	11°	P555001	
630	710	390	685	11°	P556301	

Always chamfer cut pipe and lubricate all plain ended spigots for perfect push-fit

Pozzetto d'ispezione a passaggio diretto - *Inspection chamber*
Schachtboden aus PVC (typ G) - *Pozo de registro*
Boîte de branchement direct - *Erfscheidingsput*

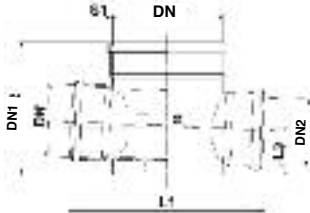

DN	DN1	DN2	S1	L1	L2	L3	α	Codice / Ref. RAL 7037 Grigio/Grey
250	100	160	4.0	406	300	110	2°	1943442
315	100	160	5.0	470	320	110	2°	1953442
250	125	125	4.0	406	300	110	2°	1943042•
315	125	125	5.0	459	320	115	2°	1953042•
250	160	160	4.0	436	300	110	2°	1943242•
315	160	160	5.0	491	320	115	2°	1953242•
400	160	160	7	570	412	148	2°	1964142•
400	200	200	7	610	412	148	2°	1964242•

• A richiesta disponibile in Rosso RAL8023 / RAL8023 available on request Guarnizione labbro montata / Lip Ring

Pozzetto d'ispezione sifonato - *Trapped inspection chamber*
Schachtboden mit Siphon - *Pozo de registro sifónico*
Boîte de branchement siphonide - *Inspektieput met waterslot*

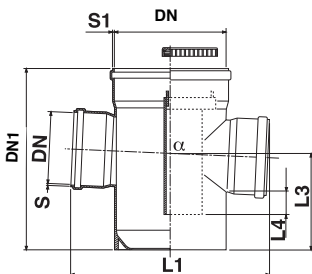

DN	DN1	S	L1	L2	L3	L4	α	Codice / Ref. RAL 7037 Grigio/Grey
250	125	4.0	406	405	215	67.5	2°	1944642
315	125	5.0	459	422	217	67.5	2°	1954642
250	160	4.0	436	405	215	50	2°	1944842
315	160	5.0	491	422	217	50	2°	1954842

Guarnizione labbro montata / Lip Ring

Pozzetto d'ispezione rompiflusso

Inspection chamber with c. baffle - *Schachtboden mit Prallplatte*
Schachtboden mit Prallplatte - *Pozo de registro desconector*
Boîte de branchement disconnectrice - *Inspektieput met remschot*

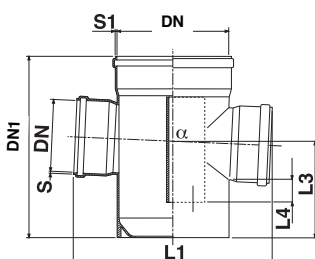

DN	DN1	S	L1	L2	L3	L4	α	Codice / Ref. RAL 7037 Grigio/Grey
250	125	4.0	406	405	215	67.5	2°	1943842
315	125	5.0	459	422	217	67.5	2°	1953842
250	160	4.0	436	405	215	50	2°	1944042
315	160	5.0	491	422	217	50	2°	1954042

Guarnizione labbro montata / Lip Ring

Always chamfer cut pipe and lubricate all plain ended spigots for perfect push-fit

Pozzetto d'ispezione a passaggio diretto APESANTITO

Heavy inspection chamber - Schachtboden (beschwert)
 Pozo de registro pesado - Tabouret lesté passage direct
 Erfscheidingsput

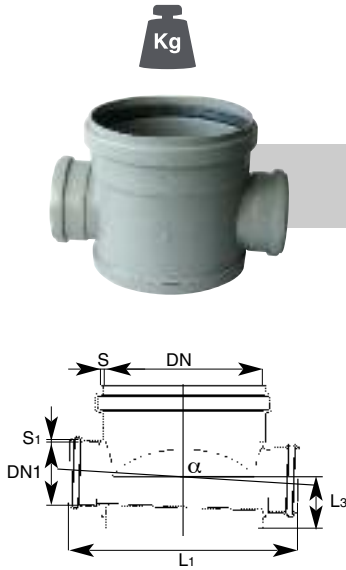

DN	DN1	S	S1	L1	L2	L3	α	Kg.	Materiale Material	Codice / Ref. RAL 7037 Grigio/Grey
315	125	4,9	3,0	459	283,5	103	2°	7,50	PP	1951242
315	160	4,9	3,6	480	316,5	119	2°	7,70	PP	1951642
315	200	4,9	4,5	505	356,5	139	2°	8,20	PP	1952042

Guarnizione labbro montata / Lip Ring

Pozzetto 400x160 MF (giunzione ad anello di tenuta)

Access junction basis - Schachtboden - Pozo de registro a 3 entradas - Regard à 3 entrées - Inspektieput



DN	DN1	S	L1	L2	L3	L4	α	Codice / Ref. RAL 8023 Rosso/Red	Note
400	160	5	74	85	275	605	45°	196435X	3E.M/F - RML

Guarnizione labbro montata / Lip Ring

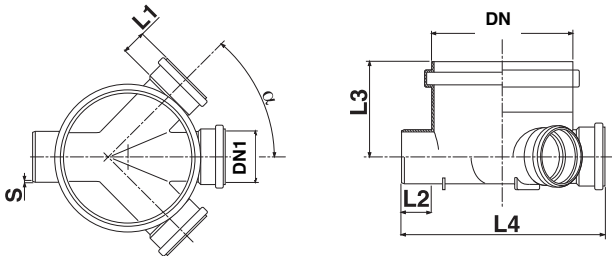

Pozzetto 400x160 MF (giunzione ad anello di tenuta)

Access junction basis - Schachtboden - Pozo de registro a 2 entradas - Regard à 2 entrées - Inspektieput



DN	DN1	S	L1	L2	L3	L4	α	Codice / Ref. RAL 8023 Rosso/Red	Note
400	160	5	74	85	275	605	0°	196495X	MF PD - G

Guarnizione labbro montata / Lip Ring

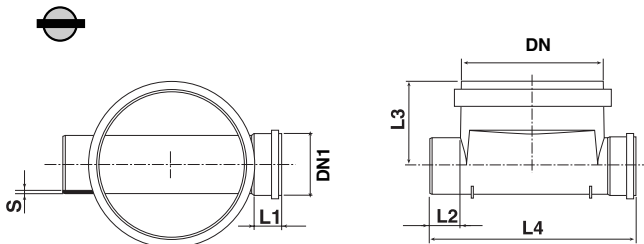

Always chamfer cut pipe and lubricate all plain ended spigots for perfect push-fit



Pozzetto 4 vie 400x200 FF (giunzione ad anello di tenuta)

Access junction basis 400x200

DN	DN1	α	H	L1	L2	Materiale Material	Codice / Ref. RAL 8023 Rosso/Red
400	200	45°	620	670	600	PP	POZ42PP

Guarnizione labbro montata / Lip Ring

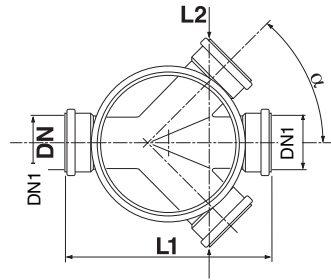
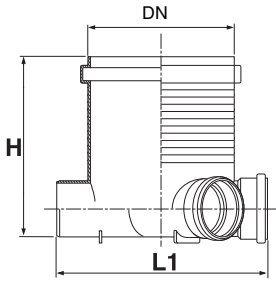

Pozzetto 400x160 MF (giunzione ad anello di tenuta)

Access junction basis - Schachtboden - Pozzo de registro a 3 entradas - Regard à 3 entrées - Inspektieput



DN	DN1	S	L1	L2	L3	L4	L5	α	Codice / Ref. RAL 8023 Rosso/Red	Note
400	160	5	74	85	13	605	23	45°	096435X	3E.M/F - RML
400	160	5	74	85	13	605	23	0°	096495X	MF PD - G

Guarnizione labbro montata / Lip Ring

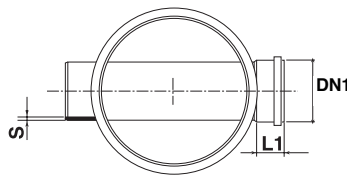
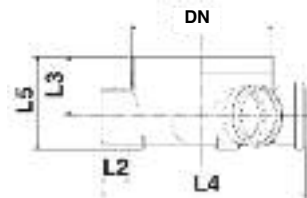
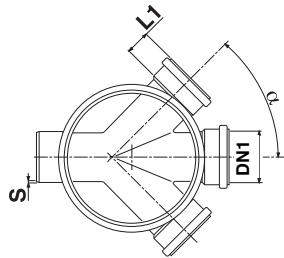

Guarnizione telescopica - Telescopic gasket - Manschette

DN	DN1	Codice / Ref.	Note
315	400	6834300	Upon request

Always chamfer cut pipe and lubricate all plain ended spigots for perfect push-fit

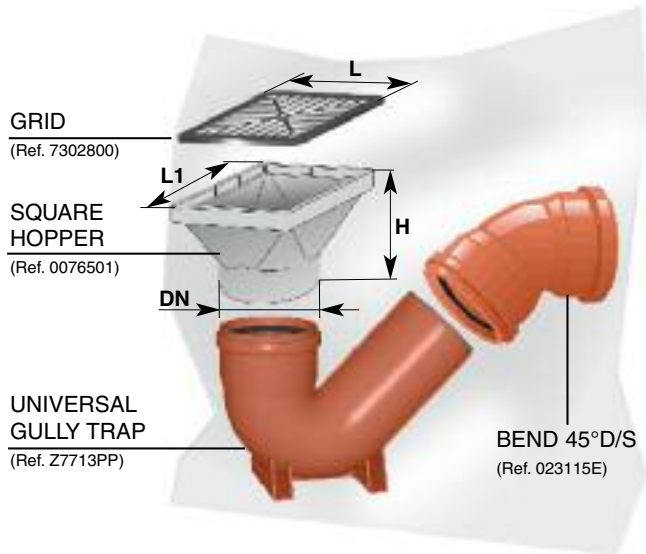

Gully Kit

Codice Ref.	Imballo Pack.	DN	H	L	L1
1KIT15E	6 Kit per carton box 48 Kits per europallett				
Codice Ref.	Note	DN	H	L	L1
7302800	Grid			150	
0076501	Square Hopper	110	99		160
023115E	Bend 45° D/S	110			
Z7713PP	Universal Gully Trap	110			



Sifone PP O-Ring - Universal Gully trap

DN	H	L	Z1	Z2	Materiale Material	Codice / Ref. RAL 8023 Rosso/Red
110	142	310	225	50*	PP	Z7713PP

Battuta sifonante 50 mm (quando installata con curva 45°) / Siphon 50mm (when fitted with 45° bend)

Guarnizione labbro montata / Lip Ring

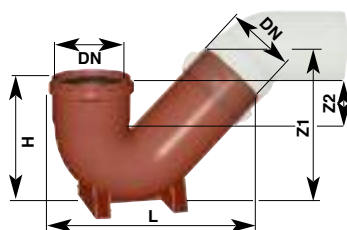

Sifone PVC - Universal Gully trap (horizontal outlet)

DN	H	L	Z1	Z2	Materiale Material	Codice / Ref. RAL 8023 Rosso/Red
110	245	360	280	120	PVC	17711S1

Guarnizione labbro montata / Lip Ring

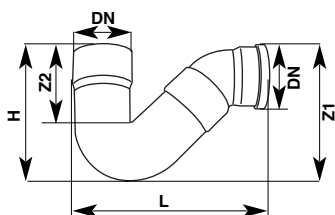

Always chamfer cut pipe and lubricate all plain ended spigots for perfect push-fit

Conessioni speciali

Cosa sono:

Sono dei dispositivi che consentono di realizzare una derivazione, come un allaccio fognario.

Come funzionano:

Vengono applicate direttamente nel punto del collettore dove deve essere realizzato l'allaccio. Consentono l'installazione grazie ad un sistema di attacco a compressione meccanica, sia sul nuovo che nelle ristrutturazioni.

A chi si rivolgono:

Sono particolarmente indicate per: Società di Gestione Sistema Idrico e Fognario, Imprese di costruzione, Municipalità, Privati.

Special sewer connections

What are they used for:

They are devices suitable for connect to a sewage pipe or a drainage pipe. They can be used both in new buildings as in renovation.

How they work:

Two types: "solvent cement" or "mechanical". They are directly installed on the collector in point where the connection is needed. The mechanical ones have a special compression fitting to be installed.

Who can be interested in:

Water Companies, Construction Companies, Municipality, Privates

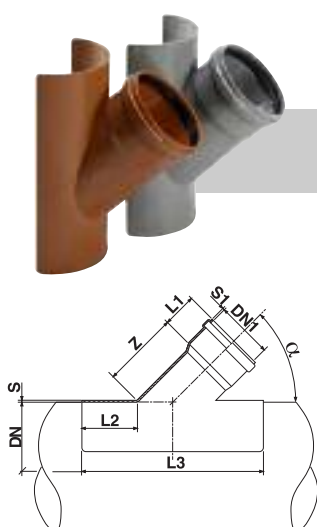

Derivazione a sella ad incollaggio a 45° - Saddle - Klebschelle Injerto montura silla - Clip à collar - Rioolaansluitzadel

DN	DN1	α	S	S1	Z	L1	L2	L3	Codice / Ref. RAL 7037 Grigio/Grey	Codice / Ref. RAL 8023 Rosso/Red
160	125	45°	3.2	3.0	128	62	65	300	0438042	0438091
200	125	45°	4.1	3.0	128	62	85	340	0438242	0438291
200	160	45°	4.1	3.6	165	73	85	390	0438442	0438491
250	125	45°	5.5	3.0	128	62	92	350	0438642	0438691
250	160	45°	5.5	3.6	165	73	92	400	0438842	0438891
315	125	45°	5.5	3.0	128	62	92	350	1439042	1439091
315	160	45°	6.9	3.6	165	73	110	432	0439442	0439491
315	200	45°	6	4.4	236	95	86	513	1433242	1433291
400	125	45°	5.5	3.0	128	62	92	350	1439142	1439191
400	160	45°	5.5	3.6	165	73	92	400	1439542	1439591
500	125	45°	5.5	3.0	128	62	92	350	1439242	1439291
500	160	45°	5.5	3.6	165	73	92	400	1439642	1439691

Guarnizione labbro bloccata / Fixed Ring Guarnizione labbro montata / Lip Ring
To be solvent welded onto the pipe

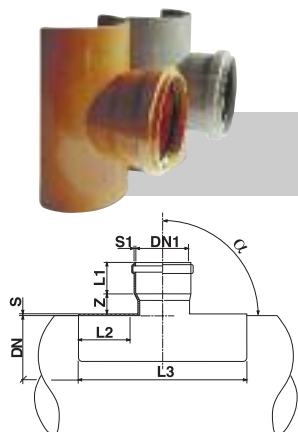

Derivazione a sella ad incollaggio 90° - Saddle - Klebschelle Injerto montura silla - Clip à collar - Rioolaansluitzadel

DN	DN1	α	S	S1	Z	L1	L2	L3	Codice / Ref. RAL 7037 Grigio/Grey	Codice / Ref. RAL 8023 Rosso/Red
200	160	90°	4.4	3.6	34	58.5	77	322	0434342	0434351
250	160	90°	4.4	3.6	34	58.5	77	322	1424242	1424251
315	160	90°	-	-	-	-	-	-	-	142525E
315	200	90°	6	4.4	45	86	75	390	1425552	-
400	160	90°	-	-	-	-	-	-	-	142625E

Guarnizione labbro bloccata / Fixed Ring Guarnizione labbro montata / Lip Ring
To be solvent welded onto the pipe

Always chamfer cut pipe and lubricate all plain ended spigots for perfect push-fit



Clip Meccanica per tubi in Gres Mechanical saddle for clay pipes

DN esterno (mm)	DN interno (mm)	DN1 (mm)	L1 (mm)	L2 (mm)	Codice/Ref.	Imb./Pack	Note
242	200*	160	341	290	1431658	48 6	* Diametro nominale Gres

* Diametro nominale Gres Guarnizione labbro montata / Lip Ring

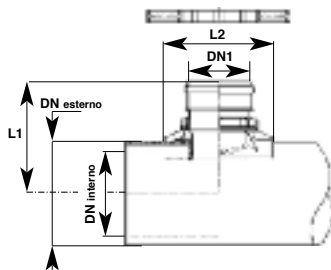

Attenzione: foro tubo in GRES Ø 150 mm

N.B. per tubi in gres sono reperibili sul mercato le opportune attrezzature di foratura.
Attention: drill size Ø 150 mm.

Warning: the specific drilling tools for clay-pipes are available on the market.

Collegamento PVC/PP/PE/KG2000 → Gres

From PVC/PP/PE/KG2000 to → Clay

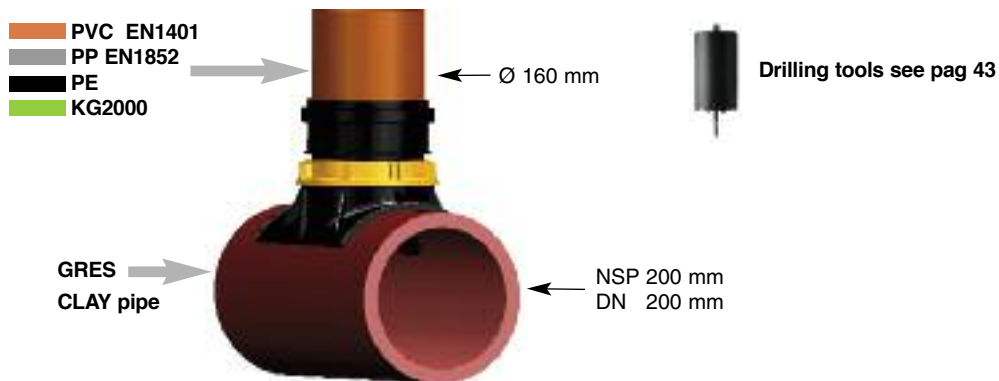

Vantaggi - Benefits

Innesto su tubo in Gres con Clip meccanica REDI

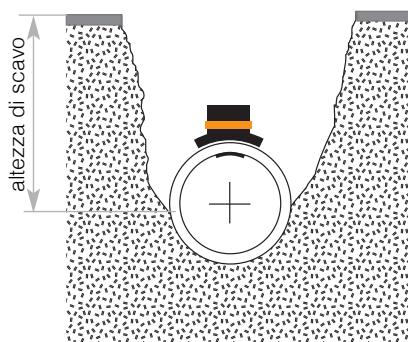

Scavo ridotto: basta arrivare al cielo della condotta. Rimane inalterato il letto di posa della fognatura esistente. Tenuta idraulica e meccanica garantita.

Innesto su tubo in Gres con presa a staffa (metodo tradizionale)

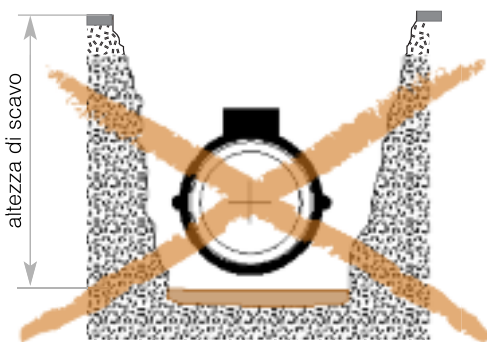

È necessario scavare sotto il livello della tubazione. Lavoro di scavo complesso e laborioso. Rischi di disassettamento alla fognatura esistente perchè si interviene sul letto di posa.

Installazione - Installation

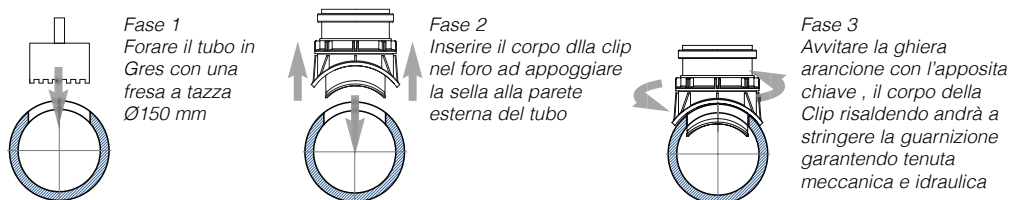

Always chamfer cut pipe and lubricate all plain ended spigots for perfect push-fit



Clip meccanica 90° per tubi plastici lisci SN2 - SN4 - SN8
Mechanical saddle 90° for smooth pipes SN2 - SN4 - SN8

DN	DN1	Codice/Ref. ↙	L1	L2	Spessore Max. Tubo	Note
250	160	1432258	285	290	8,3 mm	chiave inclusa / screwing tool included
315	160	1433358	315	290	10,4 mm	chiave inclusa / screwing tool included
400	160	1434458	360	290	13,1 mm	chiave inclusa / screwing tool included

↙ Guarnizione labbro montata / Lip Ring

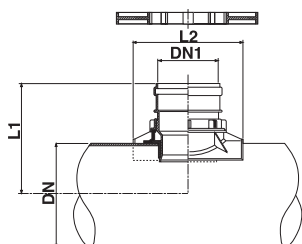

Chiave di serraggio - Screwing tool - Montageschlüssel

DN	Codice / Ref.	Note
160	0996606	CHIAVE APERTA (1 chiave per 6 pz. / included in box 6 pcs.)



Tubazione in PVC posta in opera (metodo rapido con bloccaggio meccanico)
Existing PVC main sewer (quick push-fit with mechanical fixing)

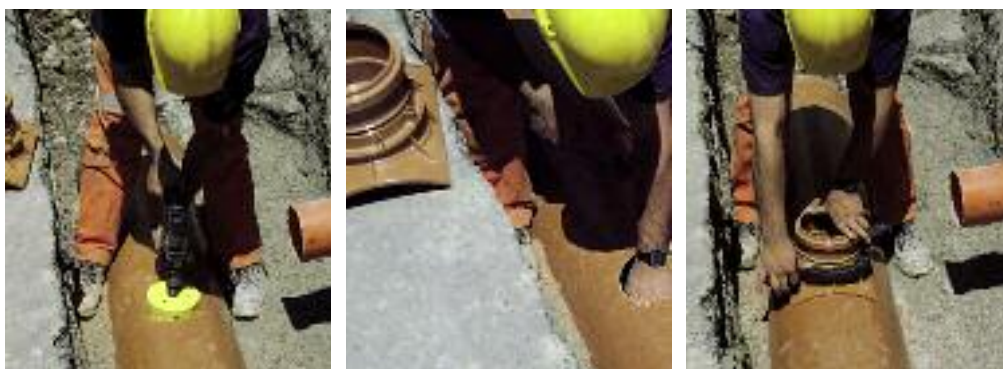

Forare il tubo pendicolarmente al suo asse con una sega a tazza: Ø=152 mm (6")

Using a suitable hole saw, drill a hole of Ø 152 mm (6") - Ensure saw cut is square to the pipe to avoid an oval cut which may result in leakage of the clip.

Sbavare il bordo del foro con una lima o una spazzola metallica

Remove swarf and clean the edges of the hole (soft abrasion). Inaccurate drilling may affect the tightness of the clip.

Avvitare la ghiera con l'apposita chiave fino al bloccaggio della derivazione ottenuta.

Using the key provided, screw the nut fully home ensuring the inner expansion gasket is compressed.

Always chamfer cut pipe and lubricate all plain ended spigots for perfect push-fit

EASY CLIP

Easy clip is not available for sale in Germany

Easy Clip permette l'esecuzione di nuovi allacciamenti (Ø160 e 200) a condotte fognarie esistenti garantendo:

- perfetta tenuta idraulica
- alta resistenza meccanica
- affidabilità nel tempo

Easy Clip universal Mechanical Saddles with Swivel:

- *Watertight and easy-to-install connection*
- *Add-on junction fully fit-for-purpose*
- *Excellent mechanical strength*
- *Great profit-earner for stockists*



Easy Clip può essere applicata a tubi di PVC ,PP o PE compatto, Cemento, PE/PP a parete strutturata.

Easy Clip mechanical saddles connect smooth plastic sewer pipes (PVC, PP, PE) to mains made from reinforced concrete, concrete, plastic (smooth and corrugated) as well as clay and GRP*.*

Easy Clip è fornita in diverse versioni in grado di garantire applicazioni a tubi aventi diametro esterno compreso tra 300 e 1000 mm con spessori fino a 100 mm (vedi tabella).

Easy Clip saddles fit sewer mains from DN 300 mm up to DN 1000 mm with wall thickness up to 100 mm Inlet 160mm (inc. swivel) and 200mm (dimensions in charts).

Caratteristiche principali del prodotto *Easy Clip Mechanical Saddles: strenghts and benefits*

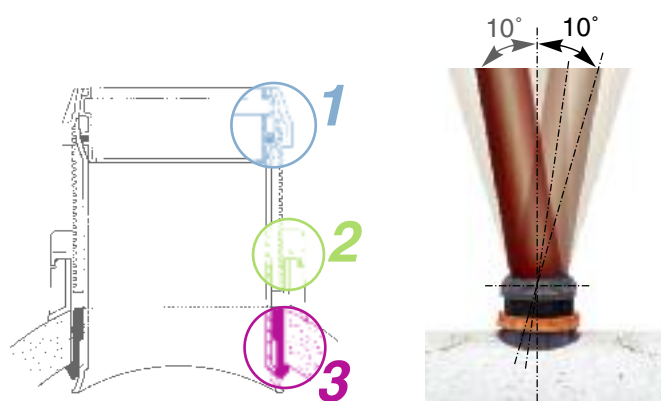

1) Rotola di compensazione degli assestamenti laterali (patent pending EP 1548349 A1) nella versione d.160 (innesto conforme a EN 1401), Easy Clip è dotata di una speciale rotola di compensazione la cui sede è ottenuta dall'accoppiamento di 2 semisfere ricavate sul corpo e sulla ghiera superiore di bloccaggio. Il prodotto viene fornito da Redi montato, prelubrificato e pronto alla posa. La rotola consente di assorbire inclinazioni del tubo fino a +/-10°.

160mm Swivel, two - components swivel, pre-lubricated and ready-to-install (patent pending EP 1548349 A1). Rotation up to 10° to ease house connections and balance ground settlement. Follow instructions (included in packing).

2) Serraggio della clip, la ghiera di serraggio, di colore arancio per una rapida identificazione in cantiere, integra un elemento in teflon che riduce gli attriti, evita i grippaggi e garantisce un perfetto serraggio. Ogni clip viene fornita completa di apposita chiave di serraggio. Una volta installata, Easy Clip garantisce altissima resistenza meccanica alle sollecitazioni laterali determinate dagli inevitabili assestamenti.

Screwing and tightening, the orange nut incorporates a sliding Teflon ring to ease the tightening and ensure perfect mechanical strength thus offering a long-lasting and firm connection. A screwing key is supplied with each saddle.

3) Elemento interno di tenuta, la guarnizione mobile (pat. pending EP 1548349 A1) consente un facile e veloce inserimento del corpo nel foro praticato sul tubo. Il successivo serraggio della ghiera comprime la guarnizione garantendo la tenuta idraulica su tutti i tipi di materiale. L'ingombro finale interno risulta estremamente contenuto.

Compression of the inner elastomeric expansion gasket, the loose expansion gasket (pat. pending EP 1548349 A1) offers easy insertion of the body into the main pipe. When compressed, the special shape of the Easy Clip gasket ensures good water tightness independently of material. Internal protrusion into the main pipe is minimal and will not interfere with flow or when cleaning or rodding.

Type Ø160

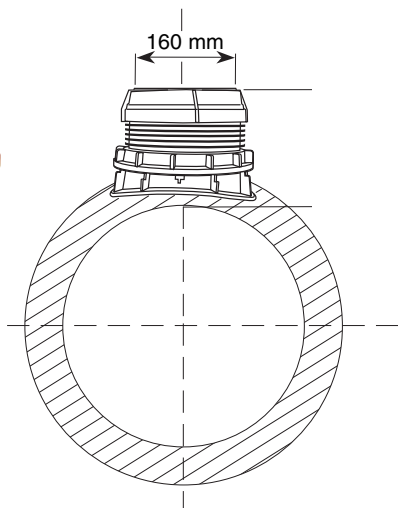

Type Ø200

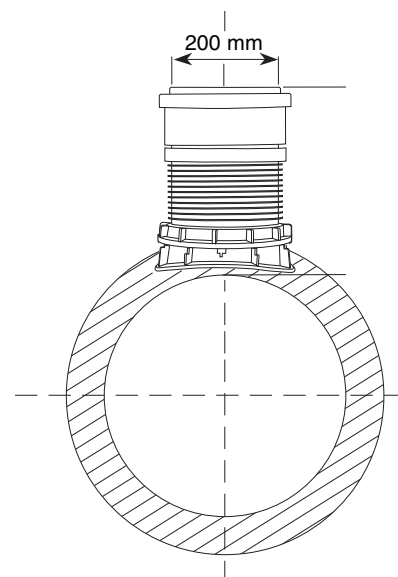

Installazione / Installation



Il foro (Ø 200 mm 0/+3 mm) deve essere eseguito con attrezzature adeguate al materiale da perforare e perpendicolarmente alla mezzera del tubo in modo da evitare ovalizzazioni che potrebbero compromettere la tenuta idraulica di Easy Clip.

Using a suitable hole saw, drill a hole of Ø 200 mm 0/+3 mm - Ensure saw cut is square to the pipe to avoid an oval cut which may result in leakage of the clip.



Inserire Easy Clip nel foro.

Insert Easy Clip into the hole making sure the inner expansion gasket is centred.

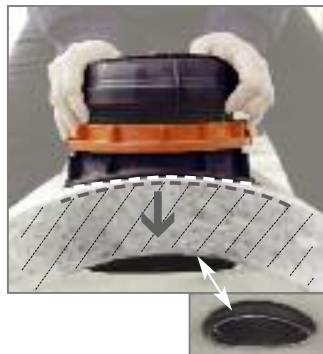

Spingere a fondo fino ad ottenere il perfetto accoppiamento fra il profilo del tubo e quello di Easy Clip.

Push gently and vertically so the saddle flange sits perfectly onto the pipe surface.



Con l'apposita chiave in dotazione ruotare la ghiera fino ad ottenere la dovuta compressione della guarnizione interna e il buon bloccaggio meccanico di Easy Clip.

Using the key provided, screw the nut fully home ensuring the inner expansion gasket is compressed.

- I** ID = Internal Diameter (il diametro del tubo si riferisce al diametro INTERNO)
OD = Outside Diameter (il diametro del tubo si riferisce al diametro ESTERNO)
S = Spessore del tubo
- GB** ID = Internal Diameter of the pipe
OD = Outside Diameter of the pipe
S = Thickness of the pipe
- D** ID = Innendurchmesser des Rohres
AD = Außendurchmesser des Rohres
S = Wandstärke des Rohres
- ES** ID = Internal Diameter (el diámetro del tubo se refiere al diámetro INTERIOR)
OD = Outside Diameter (el diámetro del tubo se refiere al diámetro EXTERIOR)
S = Espesor del tubo
- F** ID = Internal Diameter (diamètre INTERIEUR du tube)
OD = Outside Diameter (diamètre EXTERIEUR du tube)
S = Epaisseur du tube
- NL** ID = inwendige diameter van de buis
BD = buiten diameter van de buis
S = wanddikte van de buis

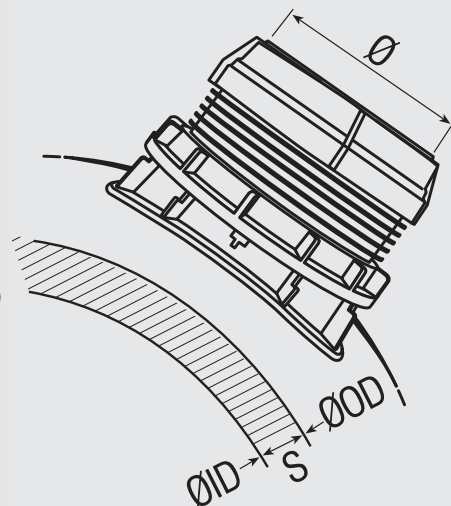

Tubi in cemento/gres ID

Reinforced concrete, and clay concrete ID
 Steinzeug- Beton- und Stahlbetonrohr nach Innendurchmesser
 Tubos de hormigón ID - Tubes en béton ID
 Beton - en gewapende betonbuizen volgens inwendige ameter ID

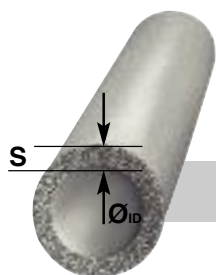

Tubo Ø ID Pipe Ø ID	300	400	500	600	700÷1200
Easy Clip Ø160 con snodo Easy Clip Ø160 with swivel	1C16058	1E16058	1H16058	1H16058	1K16058
Easy Clip Ø200	1C20058	1E20058	1H20058	1H20058	1K20058
S (mm)	40+80	30+80	40+100	40+100	50+100

Tubi in plastica a parete strutturata OD

Twin wall/corrugated plastic pipes OD
 Gewellte Kunststoffrohre nach Außendurchmesser
 Tubos de plástico corrugados OD - Tubes annelés OD
 Geribde kunststofbuizen volgens buitendiameter BD

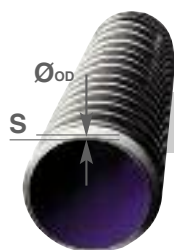

Tubo Ø OD Pipe Ø OD	315	400	500÷630	800÷1200
Easy Clip Ø160 con snodo Easy Clip Ø160 with swivel	1A16058	1D16058	1G16058	1K16058
Easy Clip Ø200	1A20058	1D20058	1G20058	1K20058
S (mm)	30 max	35 max	50 max	40+100

Tubi in plastica a parete strutturata ID

Twin wall/corrugated plastic pipes ID
 Gewellte Kunststoffrohre nach Innendurchmesser
 Tubos de plástico corrugados ID - Tubes annelés ID
 Geribde kunststofbuizen volgens inwendige diameter ID

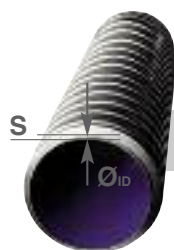

Tubo Ø ID Pipe Ø ID	300	400	500	600	700÷1200
Easy Clip Ø160 con snodo Easy Clip Ø160 with swivel	1A16058	1E16058	1G16058	1H16058	1K16058
Easy Clip Ø200	1A20058	1E20058	1G20058	1H20058	1K20058
S (mm)	30 max	30+80	50 max	40+100	40+100

Tubi in plastica a parete piena o espansi OD

Plain wall/multilayer smooth plastic pipes OD
 Glatte Kunststoffrohre nach Außendurchmesser
 Tubos de plástico con pared llena o expandida OD
 Gladde kunststofbuizen volgens buitendiameter BD

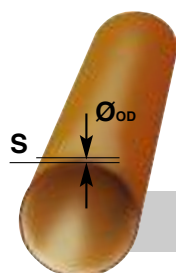

Tubo Ø OD Pipe Ø OD	315	400	500÷630	710÷1200
Easy Clip Ø160 con snodo Easy Clip Ø160 with swivel	1A16058	1D16058	1G16058	1J16058
Easy Clip Ø200	1A20058	1D20058	1G20058	1J020058
S (mm)	5÷30	6÷35	9÷50	12÷50

Ogni clip viene fornita completa di apposita chiave di serraggio.
 A screwing key is supplied with each saddle.

Attrezzature / Equipment

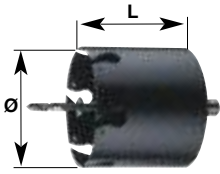

DUSS made in Germany

DN (mm)	L (mm)	Mandrino Mandren	Punta ricentro Pilot bit	Lunga durata Long endurance	Codice Ref.	Note
200	163	13mm	SI	SI	AD2013P	Tubi da Ø250 / Pipes from Ø250
152(6")	163	13mm	SI	SI	AD1513P	Tubi da Ø250 / Pipes from Ø250

Materiale: PVC / PP / PE / Legno / Fibra vetro (senza sabbia)

Material: PVC / PP / PE / Wood / GRP (sand free)

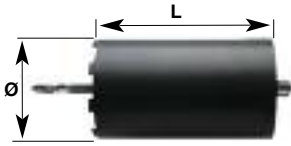

DUSS made in Germany

DN (mm)	L (mm)	Mandrino Mandren	Punta ricentro Pilot bit	Lunga durata Long endurance	Codice Ref.	Note
202	300	SDS max	SI	SI	AC2CSDZ	Tubi da Ø250 / Pipes from Ø250
150	300	SDS max	SI	SI	AC1SSDZ	Foro Ø150 solo per Clip Gres <i>Hole Ø150 only suitable for Mechanical saddle for Clay Pipe</i>

Materiale: Cemento armato / Corrugati rinforzo acciaio / Fibra di vetro caricato con sabbia / Gres

Material: Reinforced concrete / Reinforced corrugated steel / Fiber glass filled with sand / Clay concrete

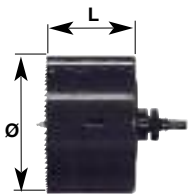

DN (mm)	L (mm)	Mandrino Mandren	Punta ricentro Pilot bit	Lunga durata Long endurance	Codice Ref.	Note
200	50	13mm	SI	NO	AO55000	Tubi diametro minimo Ø 315mm sp. max 8mm <i>Pipes diameter minimum Ø315mm thick max 8mm</i>

Materiale: PVC / PP / PE

Material: PVC / PP / PE

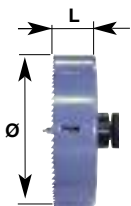

DN (mm)	L (mm)	Mandrino Mandren	Punta ricentro Pilot bit	Lunga durata Long endurance	Codice Ref.	Note
152(6")	30	13mm	SI	NO	AO53000	Tubi diametro minimo Ø 315mm sp. max 8mm <i>Pipes diameter minimum Ø315mm thick max 8mm</i>

Materiale: PVC / PP / PE

Material: PVC / PP / PE

A richiesta son disponibili macchine di perforazione ed accessori specilai (Duss made in Germany):
Available upon request special drilling machines and special tools (Duss made in Germany):



Trapano / Drill



Carotatrice / Rotary hammer



Carotatrice / Rotary hammer



Supporto per perforatrice / Drilling holder

I certificati esposti in questa pagino posso essere soggetti a revisioni ed aggiornamenti pertanto sono disponibili a richiesta i certificati aggiornati di ogni prodotto.

The certificates shown on this page may be subject to revisions and updates. Therefore available on request updated certificates for each product.



Easy Clip



Easy Clip



Easy Clip



OTTIMA Ø100÷160

REDI

Le strade dell'acqua

40069 40069 ZOLA PREDOSA - Via Madonna dei Prati, 5/A - (Bologna - Italy)

Tel. + 39 051 6175111 - Fax + 39 051 756649

e-mail: vendite.italia@redi.it - export@redi.it

www.redi.it

an *Oliaxis* company